

# Operating Instructions

## Robacta Reamer V Twin

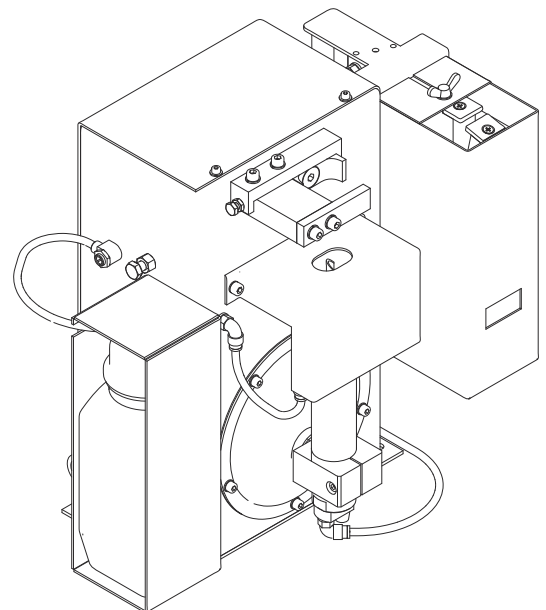

**EN** | Operating Instructions





# Contents

Safety rules.....	6
Explanation of safety notices .....	6
General.....	6
Proper use .....	7
Environmental conditions.....	7
Obligations of the operator.....	7
Obligations of personnel.....	7
Specific hazards.....	7
Protecting yourself and others.....	8
EMC Device Classifications.....	8
EMC measures.....	9
EMF measures.....	9
Safety measures at the installation location and during transport.....	9
Safety measures in normal operation.....	10
Commissioning, maintenance and repair.....	10
Safety inspection.....	10
Disposal.....	11
Safety symbols.....	11
Copyright.....	11
<b>General</b> .....	<b>13</b>
General.....	15
Principle.....	15
Device concept.....	15
Application areas.....	15
Scope of supply.....	16
Available options .....	16
How the wire cutter works/Maximum wire diameter.....	16
Warning notices on the device.....	17
Transport.....	19
Transport devices .....	19
Transport notices on the packaging.....	19
<b>Controls, connections and mechanical components</b> .....	<b>21</b>
Safety .....	23
Safety .....	23
Robacta Reamer V Twin control elements, connections and mechanical components.....	24
Control elements, connections and mechanical components .....	24
Standard I/O connecting plug (X1) pin assignment for robot control.....	26
General.....	26
Standard I/O (X1) connecting plug pin assignment.....	26
<b>Installation and commissioning</b> .....	<b>27</b>
Safety .....	29
Safety .....	29
Ensuring that the cleaning device is depressurised .....	30
Before commissioning.....	31
Proper use .....	31
Operators, maintenance personnel.....	31
Setup regulations .....	31
Compressed air supply specifications.....	31
Measures for the safe operation of the device with untrained personnel.....	32
Screwing the cleaning device to the underlying surface.....	33
Screwing the cleaning device and installation stand to the underlying surface.....	33
Screwing the cleaning device to the underlying surface.....	33
Fitting the cleaning cutter.....	35
Fitting the cleaning cutter.....	35
Torch cleaning position.....	36

Cleaning position of the welding torch with externally routed coolant lines.....	36
Cleaning position of the welding torch with internally routed coolant lines.....	36
Fitting the clamping system for welding torches with internally routed coolant lines.....	37
Tools required.....	37
Removing the existing clamping system.....	37
Fitting the Twin clamping system.....	38
Adjusting the lifting device.....	41
Adjusting the lifting device.....	41
Installing the compressed air supply.....	43
Establishing the compressed air supply for the cleaning device, function of the compressed air relief valve.....	43
Starting up the parting agent nebuliser.....	44
Fill parting agent container (1 litre) and connect to the cleaning device.....	44
Connect the parting agent container (10 litres) to the cleaning device.....	45
Adjusting the parting agent nebuliser spray amount.....	46
Using the fill-level control sensor.....	47
Optional fill-level control sensor.....	47
Controls and indicators on the sensor.....	47
Installation adapter borehole dimensions.....	47
Fitting the fill-level control sensor.....	48
Calibrating the empty state.....	49
Calibrating the full state.....	49
Locking/unlocking the fill-level control sensor.....	50
Electrical connection.....	50
Manually checking the cleaning device functions.....	51
Safety.....	51
Checking functions manually.....	51
Starting up the cleaning device.....	53
Prerequisites for start-up.....	53
Start-up.....	53
Cleaning programme.....	54
Safety.....	54
Cleaning program sequence - overview.....	55
1. Wire cutter.....	56
2. "Parting agent level" query (option).....	57
3. "Cleaning motor lowered" query.....	58
4. "Gas nozzle free" query.....	59
5. Cleaning.....	60
Signal waveform for cleaning.....	65
Signal inputs.....	65
Signal outputs.....	65
Signals not defined using time.....	66
Signal waveform: wire cutter (inputs and outputs).....	66

**Care, maintenance and disposal 67**

Safety.....	69
Safety.....	69
Care, maintenance and disposal.....	71
General.....	71
Before each start-up.....	71
Daily.....	71
Weekly.....	71
Every 6 months.....	71
As necessary.....	71
Disposal.....	72
Adjust the swivel mechanism stop angle.....	73
General.....	73
Preparatory work.....	73
Adjust the swivel mechanism stop angle.....	74
And finally.....	75

<b>Troubleshooting</b>	<b>77</b>
Safety .....	79
Safety .....	79
Troubleshooting .....	81
Errors in program sequence.....	81
<b>Technical data</b>	<b>83</b>
Technical data.....	85
Robacta Reamer V Twin .....	85
<b>Appendix</b>	<b>87</b>
Circuit diagram Robacta Reamer V Twin .....	89
Robacta Reamer V Twin pneumatic diagram .....	90
Declaration of conformity .....	91

# Safety rules

---

## Explanation of safety notices

### **DANGER!**

**Indicates immediate danger.**

- ▶ If not avoided, death or serious injury will result.
- 

### **WARNING!**

**Indicates a potentially hazardous situation.**

- ▶ If not avoided, death or serious injury may result.
- 

### **CAUTION!**

**Indicates a situation where damage or injury could occur.**

- ▶ If not avoided, minor injury and/or damage to property may result.
- 

### **NOTE!**

**Indicates a risk of flawed results and possible damage to the equipment.**

---

## General

The device is manufactured using state-of-the-art technology and according to recognised safety standards. If used incorrectly or misused, however, it can cause:

- injury or death to the operator or a third party,
  - damage to the device and other material assets belonging to the operating company,
  - inefficient operation of the device.
- 

All persons involved in commissioning, operating, maintaining and servicing the device must:

- be suitably qualified,
  - have sufficient knowledge of automated welding, and
  - read and carefully follow these operating instructions as well as the operating instructions for all system components.
- 

The operating instructions must always be at hand wherever the device is being used. In addition to the operating instructions, attention must also be paid to any generally applicable and local regulations regarding accident prevention and environmental protection.

---

All safety and danger notices on the device

- must be in a legible state,
  - must not be damaged,
  - must not be removed,
  - must not be covered, pasted or painted over.
- 

For the location of the safety and danger notices on the device, refer to the section headed "General" in the operating instructions for the device.

Before commissioning the device, rectify any faults that could compromise safety.

**This is for your personal safety!**

<b>Proper use</b>	<p>The device is to be used exclusively for its intended purpose.</p> <hr/> <p>The device is intended solely for the mechanical cleaning of Fronius robot welding torches in automatic mode. Any use above and beyond this purpose is deemed improper. The manufacturer shall not be held liable for any damage arising from such usage.</p> <hr/> <p>Proper use includes:</p> <ul style="list-style-type: none"> <li>- carefully reading these operating instructions</li> <li>- following all the instructions and safety rules in these operating instructions</li> <li>- performing all stipulated inspection and maintenance work</li> </ul> <hr/> <p>The device is designed for use in industry and the workshop. The manufacturer accepts no responsibility for any damage caused through use in a domestic setting.</p> <hr/> <p>The manufacturer likewise accepts no liability for inadequate or incorrect results.</p>
<b>Environmental conditions</b>	<p>Operation or storage of the device outside the stipulated area will be deemed as not in accordance with the intended purpose. The manufacturer shall not be held liable for any damage arising from such usage.</p> <hr/> <p>Ambient temperature range:</p> <ul style="list-style-type: none"> <li>- during operation: 0 °C to + 40 °C (32 °F to 104 °F)</li> <li>- during transport and storage: -25 °C to +55 °C (-13 °F to 131 °F)</li> </ul> <hr/> <p>Relative humidity:</p> <ul style="list-style-type: none"> <li>- up to 50 % at 40 °C (104 °F)</li> <li>- up to 90 % at 20 °C (68 °F)</li> </ul> <hr/> <p>Keep ambient air free from dust, acids, corrosive gases and substances, etc.</p> <hr/> <p>Can be used at altitudes of up to 2000 m (6500 ft)</p>
<b>Obligations of the operator</b>	<p>The operator must only allow persons to work with the device who:</p> <ul style="list-style-type: none"> <li>- are familiar with the fundamental instructions regarding safety at work and accident prevention and have been instructed in how to use the device</li> <li>- have read and understood these operating instructions, especially the section "safety rules", and have confirmed as much with their signatures</li> <li>- are trained to produce the required results.</li> </ul> <hr/> <p>Checks must be carried out at regular intervals to ensure that operators are working in a safety-conscious manner.</p>
<b>Obligations of personnel</b>	<p>Before using the device, all persons instructed to do so undertake:</p> <ul style="list-style-type: none"> <li>- to observe the basic instructions regarding safety at work and accident prevention</li> <li>- to read these operating instructions, especially the "Safety rules" section and sign to confirm that they have understood them and will follow them.</li> </ul> <hr/> <p>Before leaving the workplace, ensure that people or property cannot come to any harm in your absence.</p>
<b>Specific hazards</b>	<p>Stay out of the working area of the robot.</p>

The device must be incorporated into a higher-level safety system within a secured area.

---

If this area has to be accessed when setup and maintenance work is carried out, make sure that

- the entire system is switched off for the duration of the work in this area
  - and that it is prevented from starting up accidentally, e.g. as the result of a control fault.
- 

If untrained operators have access to the device, its compressed air supply must be disconnected for the duration of work in accordance with "Performance Level d" of the ISO 13849-1 standard.

---

In addition to these Operating Instructions, the safety rules issued by the robot manufacturer must also be observed.

---

Keep your body, especially your hands, face, hair, clothing and all tools away from moving parts, such as:

- rotating cleaning cutter
  - upwards/downwards travelling cleaning motor
  - extending/retracting gas nozzle clamping device
  - wire cutter
- 

Do not touch cleaning cutters immediately after use - risk of burns. Observe the special safety rules in the Operating Instructions for handling cleaning cutters.

---

Protect hands, face and eyes against flying parts (shavings, etc.) and compressed air/parting agent mixture escaping from the parting-agent injection nozzle.

---

Covers may only be opened/removed for the duration of any maintenance, installation or repair work.

---

During operation

- Ensure that all covers are closed and fitted properly
  - Keep all covers closed
- 

## **Protecting yourself and others**

Anyone working with the device exposes themselves to numerous risks. In addition to these Operating Instructions, the safety rules of the manufacturer of the entire welding system must also be observed.

Keep all persons, especially children, out of the working area while any devices are in operation or welding is in progress. If, however, there are people in the vicinity:

- Make them aware of all the dangers and health risks (crushing from mechanically-powered parts, injury from cleaning cutter, flying shavings and similar matter, escaping compressed air/parting agent mixture, flying sparks, dazzling by arc, inhaling of harmful welding fumes, noise, possible danger from mains or welding current, etc.)
  - Provide suitable protective equipment
  - Alternatively, erect suitable safety screens/curtains
- 

## **EMC Device Classifications**

Devices in emission class A:

- Are only designed for use in industrial settings
  - Can cause line-bound and radiated interference in other areas
- 

Devices in emission class B:

- Satisfy the emissions criteria for residential and industrial areas. This is also true for residential areas in which the energy is supplied from the public low-voltage mains.
-



---

**EMC measures**

In certain cases, even though a device complies with the standard limit values for emissions, it may affect the application area for which it was designed (e.g. when there is sensitive equipment at the same location, or if the site where the device is installed is close to either radio or television receivers).

If this is the case, then the operator is obliged to take appropriate action to rectify the situation.

---

Check for possible problems, and check and evaluate neighbouring devices' resistance to interference according to national and international requirements:

- Safety devices
- Power, signal and data transfer lines
- IT and telecommunications devices
- Measuring and calibrating devices

---

Supporting measures for avoidance of EMC problems:

1. Mains supply
  - If electromagnetic interference arises despite correct mains connection, additional measures are necessary (e.g. use a suitable line filter).
2. Control lines
  - must be kept as short as possible
  - must run close together (to avoid EMF problems)
  - must be kept well apart from other leads
3. Equipotential bonding
4. Shield, if necessary
  - Shield off other nearby devices
  - Shield off entire welding installation

---

**EMF measures**

Electromagnetic fields may pose as yet unknown risks to health:

- Effects on the health of persons in the vicinity, e.g. those with pacemakers and hearing aids
- Individuals with pacemakers must seek advice from their doctor before approaching the device or any welding that is in progress
- For safety reasons, maintain as large a distance as possible between the welding power-leads and the head/torso of the welder
- Do not carry welding power-leads and hosepacks over the shoulders or wind them around any part of the body

---

**Safety measures at the installation location and during transport**

A device toppling over could easily kill someone. Place the device horizontally on a level, firm and solid surface and anchor it securely to prevent it toppling over.

---

Special regulations apply in rooms at risk of fire or explosion

- Observe relevant national and international regulations.

---

Use internal directives and checks to ensure that the workplace environment is always clean and clearly laid out.

---

When transporting the device, observe the relevant national and local guidelines and accident prevention regulations. This applies especially to guidelines regarding the risks arising during transport.

---

After transporting the device, it must be visually inspected for damage before commissioning. Any damage must be repaired by trained service technicians before commissioning the device.

---

**Safety measures in normal operation**

Only operate the device if all safety devices are fully functional. If the safety devices are not fully functional, there is a risk of

- injury or death to the operator or a third party,
- damage to the device and other material assets belonging to the operator,
- inefficient operation of the device.

---

Any safety devices that are not functioning properly must be repaired before switching on the device.

---

Never bypass or disable safety devices.

---

Before switching on the device, ensure that no one is likely to be endangered.

---

Check the device at least once a week for obvious damage and proper functioning of safety devices.

- 
- Only use suitable original parting agent from the manufacturer.
  - Observe the information on the parting agent safety data sheet when handling parting agent. The parting agent safety data sheet may be obtained from your service centre or downloaded from the manufacturer's website.
  - Do not mix the manufacturer's parting agent with other parting agents.
  - If damage results from using a different parting agent, the manufacturer accepts no liability. In addition, no warranty claims will be entertained.
  - Used parting agent must be disposed of properly in accordance with the relevant national and international regulations.
- 

---

**Commissioning, maintenance and repair**

It is impossible to guarantee that bought-in parts are designed and manufactured to meet the demands made of them, or that they satisfy safety requirements.

- Use only original spare and wearing parts (also applies to standard parts).
- Do not carry out any modifications, alterations, etc. to the device without the manufacturer's consent.
- Components that are not in perfect condition must be replaced immediately.
- When ordering, please give the exact designation and part number as shown in the spare parts list, as well as the serial number of your device.

---

The housing screws provide the ground conductor connection for earthing the housing parts.

Only use original housing screws in the correct number and tightened to the specified torque.

---

**Safety inspection**

The manufacturer recommends that a safety inspection of the device is performed at least once every 12 months.

---

A safety inspection should be carried out by a qualified electrician

- after any changes are made
- after any additional parts are installed, or after any conversions
- after repair, care and maintenance has been carried out
- at least every twelve months.

---

For safety inspections, follow the appropriate national and international standards and directives.

---

Further details on safety inspection and calibration can be obtained from your service centre. They will provide you on request with any documents you may require.

---

**Disposal**

Waste electrical and electronic equipment must be collected separately and recycled in an environmentally responsible manner in accordance with the EU Directive and national law. Used equipment must be returned to the distributor or through a local, authorised collection and disposal system. Proper disposal of the old device promotes sustainable recycling of material resources. Ignoring this may lead to potential health/environmental impacts.

**Packaging materials**

Collected separately. Check your municipality's regulations. Reduce the volume of the box.

---

**Safety symbols**

Devices with the CE mark satisfy the essential requirements of the applicable directives (e.g. low-voltage and electromagnetic compatibility directives, machinery directive).

Devices with the CSA test mark satisfy the requirements of the relevant standards in Canada and the USA.

---

**Copyright**

Copyright of these operating instructions remains with the manufacturer.

---

The text and illustrations are all technically correct at the time of printing. We reserve the right to make changes. The contents of the operating instructions shall not provide the basis for any claims whatsoever on the part of the purchaser. If you have any suggestions for improvement, or can point out any mistakes that you have found in the instructions, we will be most grateful for your comments.



# General



## Principle

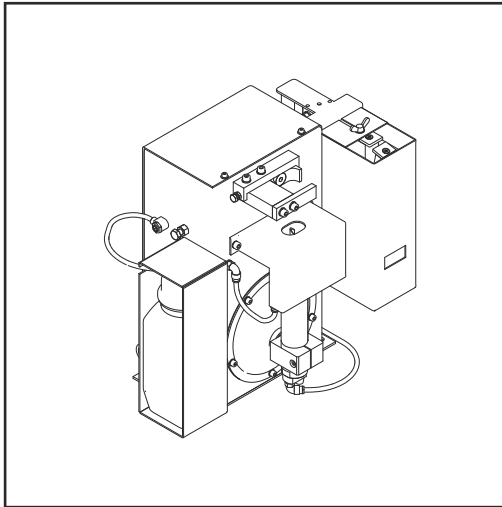

The Robacta Reamer V Twin is used for the automatic cleaning of MIG/MAG welding torches. The Robacta Reamer V Twin allows you to clean the inside and front of the gas nozzle on a wide range of welding torch shapes. The result is a significant increase in the service life of wearing parts. At the same time, evenly applying parting agent prevents the build-up of dirt.

## Device concept

The clamping device on the front of the Robacta Reamer V Twin holds the gas nozzle in place during cleaning. A cleaning cutter is used to clean the nozzle. After the cleaning process, a parting agent is applied to the inside and front of the gas nozzle through the spray nozzle that is fixed in the middle of the cleaning motor.

The Robacta Reamer V Twin is fitted with a wire cutter as standard. During the cleaning process, the Robacta Reamer V Twin shortens both wire electrodes to a defined length ready for the next welding process.

A robust fitting base is available for the installation of the Robacta Reamer V Twin.

## Application areas

The cleaning device is exclusively intended for use in robot and other automated applications, and can be used for a wide range of materials.

The main application areas are:

- Automotive and component supply industry
- Equipment construction
- Chemical plant construction
- Machine and tracked vehicle manufacturing
- Construction machinery and special vehicles

### NOTE!

**TWIN welding torches with a contact tip tilt angle of 4° cannot be cleaned with the Robacta Reamer V Twin!**

Alternatives:

- ▶ Robacta Reamer Single/Twin  
or
- ▶ Robacta TC 2000 Twin

---

## Scope of supply

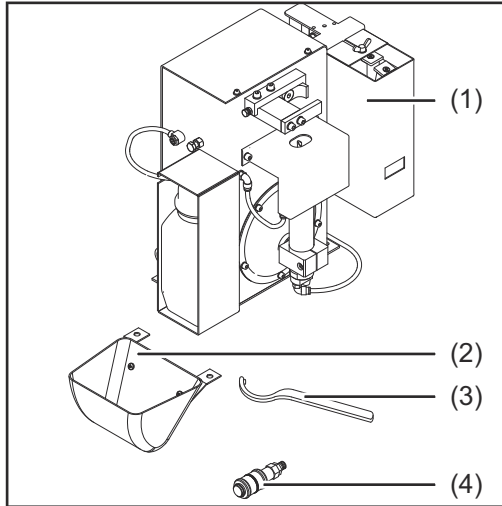

### NOTE!

The "Robacta Reamer" parting agent (item number 42,0411,8042) and the cleaning cutter are not part of the scope of supply.

- 
- (1) Robacta Reamer V Twin cleaning device with wire cutter
  - (2) Spatter tray
  - (3) Tightening key for cleaning motor
  - (4) Compressed air relief valve

not shown:

- (5) Standard I/O connecting plug (X1) without cable
- (6) Operating instructions
- (7) Fixings for assembling the cleaning device:
  - 4 screws
  - 4 washers
  - 4 lock washers
  - 4 nuts

---

## Available options

The following options are available for the cleaning device:

- Installation stand
- Cleaning cutter adjustment aid
- Level sensor

---

## How the wire cutter works/ Maximum wire diameter

The wire cutter opens and closes when there is an active signal from the robot control.

Two wire electrodes with a diameter of up to 1.6 mm (0.063 in.) can be cut at the same time by the cleaning device wire cutter.

### NOTE!

**If you change over to a new welding torch, the wire cutter must be reset!**

---



**Warning notices on the device**

The Robacta Reamer V Twin is fitted with warning notices and a rating plate. The warning notices and rating plate must not be removed or painted over.

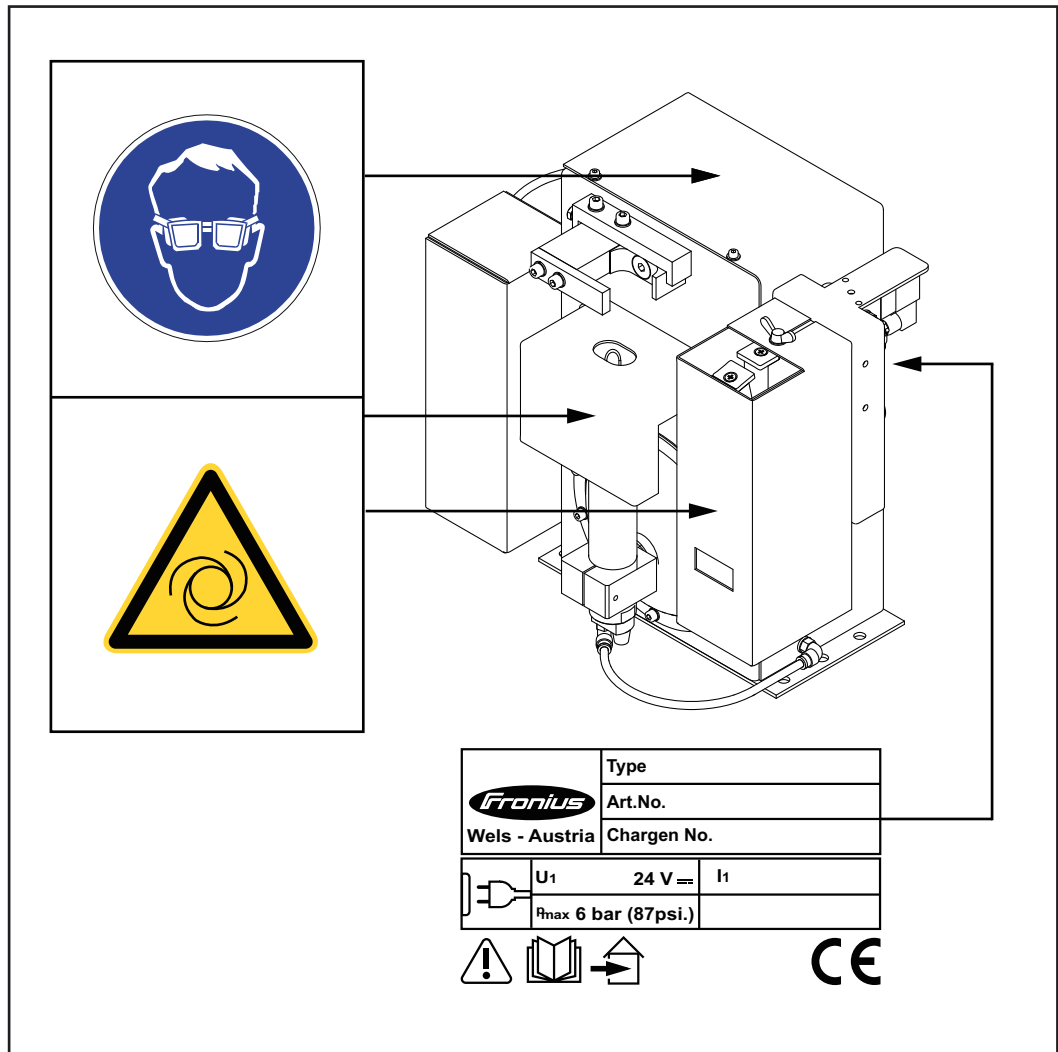

Warning notices affixed to the Robacta Reamer V Twin



**WARNING!** Risk of serious injury from:

- mechanically powered parts
- compressed air/parting agent mixture escaping from the parting-agent injection nozzle
- flying parts (shavings, etc.)

Keep device free from current and pressure during maintenance and servicing.



Do not use the functions described here until you have thoroughly read and understood the following documents:

- these operating instructions
- all the operating instructions for the system components, especially the safety rules

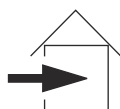

For indoor use only



Wear eye protection



Notice warning of automatic start-up of the device

---

# Transport

---

## Transport devices

The device is to be transported by the following devices:

- On pallets using a forklift truck
- On pallets using a lift truck
- Manual

 **WARNING!**

**Danger from machines and objects falling.**

This can result in serious injury and damage to property.

- ▶ Secure the device to prevent it from falling over when transporting on a forklift truck or lift truck.
  - ▶ Avoid sudden changes in direction, braking or acceleration.
- 

## Transport notices on the packaging

 **CAUTION!**

**Danger due to improper transport.**

This can result in damage to property.

- ▶ Observe the transport notices on the device packaging.
-



# **Controls, connections and mechanical components**



## Safety

Observe the following safety rules when using all functions described in the "Controls, connections and mechanical components" section.



### **WARNING!**

#### **Danger from incorrect operation!**

This can result in serious injury and damage to property.

- ▶ The functions described must only be used by trained and qualified personnel.
  - ▶ Do not use the functions described here until you have fully read and understood the following documents:  
these Operating Instructions,  
all the Operating Instructions for the system components, especially the safety rules
-

# Robacta Reamer V Twin control elements, connections and mechanical components

## Control elements, connections and mechanical components

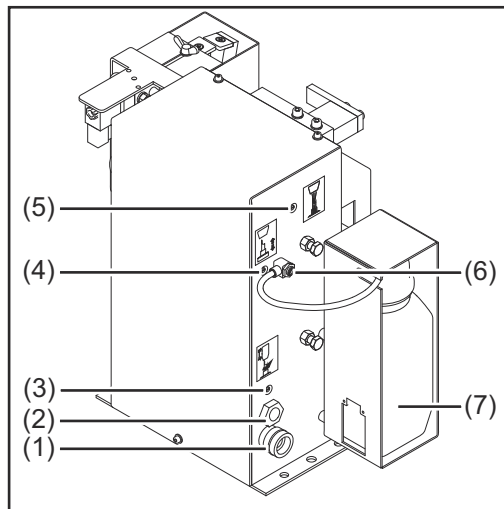

Side view

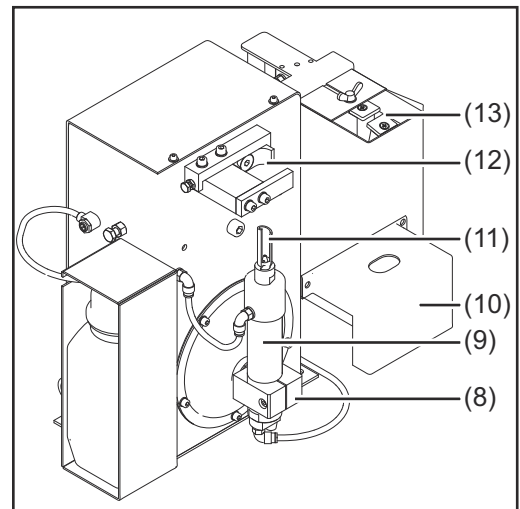

Front view

### (1) Standard I/O connection socket (X1)

For a + 24 V DC supply



### CAUTION!

#### Danger from overcurrent.

Damage to the standard I/O (X1) connection supply may result.

- Secure supply against overcurrent with a 500 mA slow-blow fuse.

### (2) Compressed air connection

For a compressed air supply at 6 bar (86.99 psi)

Compressed air connection thread identification: G ¼"

### (3) "Clamp gas nozzle/Cleaning motor on" screw

For manually checking the gas nozzle clamping device and the cleaning motor (gas nozzle clamping device extends/retracts, cleaning motor off/on)

### (4) "Lifting device up/down" screw

For manually checking the lifting device (lifting device moves up/down)

### (5) "Spray parting agent" screw

For manually checking the spray device (compressed air or compressed air/parting agent mixture is sprayed out of the parting-agent injection nozzle)

### (6) Parting agent adjuster

For setting the amount of parting agent applied

### (7) Parting agent container

### (8) Lifting device

Lifts the cleaning motor and the cleaning cutter when cleaning the inside of the gas nozzle



---

**(9) Cleaning motor with parting-agent injection nozzle**

The cleaning motor drives the cleaning cutter

---

**(10) Protective cover****(11) Cleaning cutter**

With internal through hole for the parting-agent injection nozzle

---

**(12) Gas nozzle clamping device**

Holds the gas nozzle in place during cleaning

---

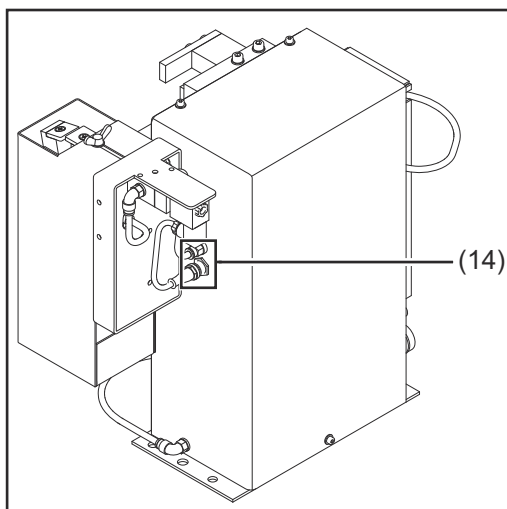
**(13) Wire cutter**

Side view

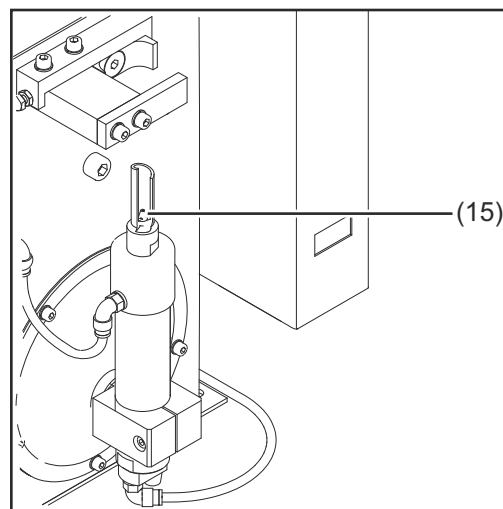

---

**(14) Compressed air and electrical connection for the wire cutter****(15) Parting-agent injection nozzle**

Applies the parting agent to the inside and front of the gas nozzle

---

# Standard I/O connecting plug (X1) pin assignment for robot control

## General

### CAUTION!

#### Danger from overcurrent.

Damage to the standard I/O (X1) connection supply may result.

- ▶ Secure the power supply of the cleaning device against overcurrent with a 500 mA slow-blow fuse.

### NOTE!

To avoid malfunction, keep the cable length between the cleaning device and robot control as short as possible.

The standard I/O (X1) connecting plug for connecting the cleaning device to the robot control is part of the scope of supply. The cable harness must be adapted to the connection technology on the robot control.

## Standard I/O (X1) connecting plug pin assignment

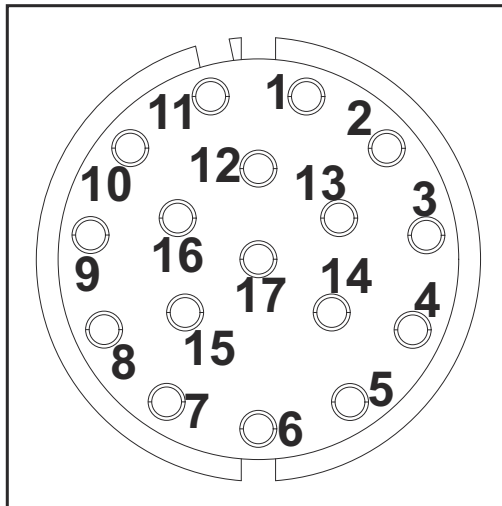

Standard I/O (X1) connecting plug pin assignment - cable-end view

Input and output signals on the Robacta Reamer V Twin:

1. Clamp gas nozzle/Cleaning motor ON (cleaning cutter turning) input signal + 24 V DC
2. GND general
3. Cleaning motor UP input signal (cleaning cutter moves to cleaning position) + 24 V DC
4. Spray parting agent input signal + 24 V DC
5. + 24 V DC (supply)
6. Gas nozzle free output signal
7. Gas nozzle clamped output signal
8. Not assigned
9. Parting agent level OK output signal
10. Cleaning motor lowered output signal (cleaning cutter in start position)
11. Cleaning motor raised output signal (cleaning cutter in cleaning position)
12. Cut wire electrode input signal + 24 V DC
13. Swivel mechanism left output signal
14. Swivel mechanism right output signal
15. Move swivel mechanism to the left input signal
16. Move swivel mechanism to the right input signal
17. Not assigned

# **Installation and commissioning**



## Safety

Observe the following safety rules for all work described in the "Installation and commissioning" section.

### **WARNING!**

#### **Danger due to incorrect operation and incorrectly performed work.**

This can result in serious injury and damage to property.

- ▶ All activities described in these Operating Instructions may only be carried out by trained and qualified personnel.
- ▶ All functions described in these Operating Instructions may only be used by trained and qualified personnel.
- ▶ Do not carry out any of the work or use any of the functions described until you have fully read and understood the following documents:  
these Operating Instructions,  
all the Operating Instructions for the system components, especially the safety rules.

### **WARNING!**

#### **Risk of machines starting automatically!**

This can result in serious injury and damage to property.

- ▶ In addition to these Operating Instructions, also observe the safety rules issued by the manufacturer of the robot and welding system.
- ▶ Ensure that all protective measures have been taken and will remain in place while you are in the working area of the robot.

### **WARNING!**

#### **Danger from mechanically powered parts, flying parts (shavings, etc.) and compressed air/parting agent mixture escaping from the parting-agent injection nozzle.**

This can result in severe injuries.

- ▶ Before carrying out any work on the cleaning device or the connected system components, disconnect the customer's compressed air and power supplies from the cleaning device and the connected system components, and ensure that they remain disconnected until all work is complete.

**IMPORTANT!** Observe the following section "Ensuring that the cleaning device is depressurised".



## WARNING!

### **Danger from power supply and/or compressed air supply to the cleaning device!**

The following conditions can lead to serious injuries:

rotating cleaning cutters

lifting device moving up/down

extending/retracting gas nozzle clamping device

activated wire cutter

flying parts (shavings, etc.)

compressed air/parting agent mixture escaping from the parting-agent injection nozzle

If work has to be performed on the cleaning device while it is being supplied with voltage and/or compressed air:

- ▶ keep your body, especially your hands, face, hair, any objects and all clothing away from the cleaning cutter, lifting device, gas nozzle clamping device, wire cutter and parting-agent injection nozzle
- ▶ Wear ear protection
- ▶ Wear protective goggles with side protection

---

### **Ensuring that the cleaning device is depressurised**

Attempt to briefly activate the cleaning device without any compressed air supply to check whether the cleaning device is depressurised. Proceed as follows:

- 1** Take protective measures:
  - The cleaning cutter, lifting device, gas nozzle clamping device, wire cutter and parting-agent injection nozzle could start up. Therefore keep your body, especially your hands, face and hair, any objects and all clothing away from the parts referred to above
  - Wear ear protection
  - Wear protective goggles with side protection
- 2** Ensure that the cleaning device has been disconnected from the compressed air supply
- 3** Briefly turn the "Lifting device up/down" screw on the Robacta Reamer V Twin 90° to the right, then turn it straight back to its original position.
  - If the cleaning device does not respond to the turning of the screw, the cleaning device is depressurised
  - If the cleaning device responds to the turning of the screw, the cleaning device is still connected to a compressed air supply. If this is the case, you must disconnect the cleaning device from the compressed air supply and check again that the cleaning device is depressurised before starting work

# Before commissioning

## Proper use

The cleaning device is to be used exclusively for cleaning Fronius robot welding torches, especially the gas nozzle and its interior, in automatic mode and within the scope of the technical data. Any use above and beyond this purpose is deemed improper. The manufacturer shall not be held liable for any damage arising from such usage.

Proper use includes:

- carefully reading these operating instructions
- following all the instructions and safety rules in these operating instructions
- performing all stipulated inspection and maintenance work

## Operators, maintenance personnel

### **WARNING!**

#### **Risk of machines starting automatically.**

This can result in serious injury and damage to property.

- ▶ The device must only be operated/serviced by 1 person at a time.
- ▶ Ensure that there is only 1 person within the working area of the device when the device is being worked on.

## Setup regulations

The cleaning device is tested to protection class IP 21, meaning:

- Protection against penetration by solid foreign bodies with diameters > 12.5 mm (0.49 in.)
- No protection against the ingress of water

The device must not be set up and operated outdoors. The built in electrical parts must be protected from direct wetting.

### **WARNING!**

#### **Danger from machines falling or toppling over.**

This can result in serious injury and damage to property.

- ▶ Always secure the cleaning device to the underlying surface.

## Compressed air supply specifications

To ensure that the cleaning device functions correctly, the following compressed air supply specifications must be met:

- Establish compressed air supply using a pressure limiter and compressed air filter
- Provide compressed air quality conforming to ISO 8573-1:2001, class 7 4 3, instrument air
  - Solid particle concentration  $\leq 10 \text{ mg/m}^3$
  - Vapour pressure dew point  $\leq + 3 \text{ }^\circ\text{C}$
  - Oil concentration  $\leq 1 \text{ mg/m}^3$

---

**Measures for the safe operation of the device with untrained personnel**

If untrained operators have access to the device, its compressed air supply must be disconnected for the duration of work in accordance with 'Performance Level d' of the ISO 13849-1 standard.

To ensure that the compressed air supply is interrupted as required, MS6-SV pressure build-up and pressure relief valves from FESTO are recommended.



# Screwing the cleaning device to the underlying surface

## Screwing the cleaning device and installation stand to the underlying surface

### **WARNING!**

#### **Danger from machines toppling over or falling.**

This can result in serious personal injury and damage to property.

- ▶ Different fixings may be required to set up the installation stand depending on the type of underlying surface (foundation).
- ▶ Fixings are therefore not included in the scope of supply of the installation stand. The installer is responsible for selecting the right type of fixing.

- 1** Place the optionally available installation stand on a level, firm and vibration-free surface (foundation)
  - Position the installation stand in such a way that the distance the robot has to travel to the cleaning device on the installation stand is as short as possible
- 2** Screw the installation stand to the underlying surface (foundation) using the appropriate fixings

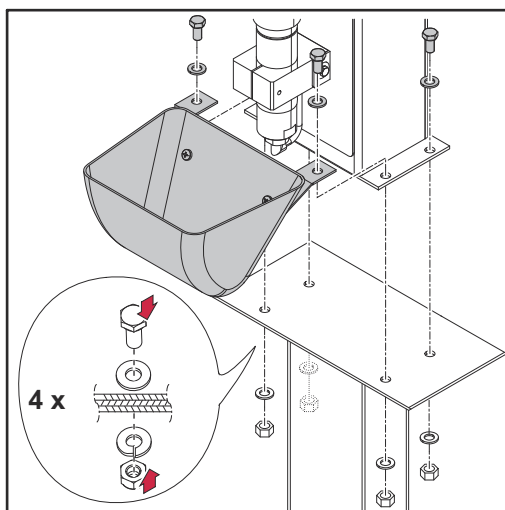

- 3** Position the cleaning device on the installation stand
- 4** Position the spatter tray on the cleaning device as shown
- 5** Securely screw the cleaning device and spatter tray to the installation stand as shown. Use the fixings supplied with the cleaning device

## Screwing the cleaning device to the underlying surface

### **WARNING!**

#### **Different fixings may be required to set up the device depending on the type of underlying surface (foundation).**

The fixings supplied may only be used on an underlying surface (foundation) thickness of 5 mm (0.197 in.) or less.

Do not use the fixings supplied to set up the device on an underlying surface (foundation) thickness greater than 5 mm (0.197 in.). In this situation the installer is responsible for selecting the right type of fixing.

- 1** Place the cleaning device on a level, firm and vibration-free surface (foundation)
  - Position the cleaning device in such a way that the distance the robot has to travel to the cleaning position is as short as possible

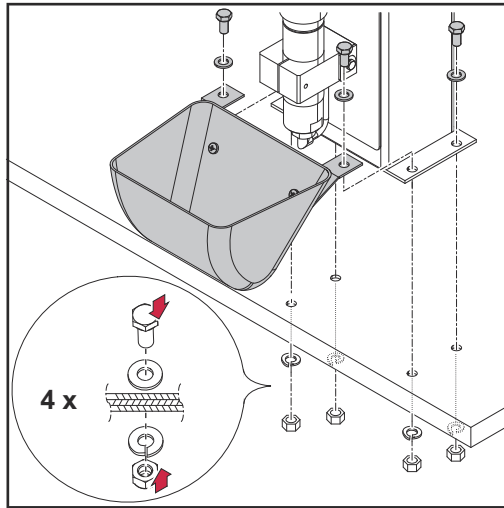

- 2 Position the spatter tray on the cleaning device as shown

For an underlying surface (foundation) thickness of less than 5 mm (0.197 in.):

- 3 Securely screw the cleaning device and spatter tray to the underlying surface (foundation) as shown using the fixings supplied

For an underlying surface (foundation) thickness greater than 5 mm (0.197 in.) or an installation different to that shown above:

- 3 Securely screw the cleaning device and spatter tray to the underlying surface (foundation) using the appropriate fixings chosen

# Fitting the cleaning cutter

## Fitting the cleaning cutter

**⚠ CAUTION!**

**Danger due to cleaning cutter that has become very hot through use.**

This can result in severe burns.

- ▶ Before handling cleaning cutters, allow cleaning cutter to cool to room temperature (+25 °C, +77 °F).

**⚠ CAUTION!**

**Danger from incompatible wearing parts.**

This can result in damage to property and malfunctions.

- ▶ Only use the device manufacturer's contact tips, gas nozzles and cleaning cutters. No liability is accepted for damage caused by the use of contact tips, gas nozzles or cleaning cutters from third-party manufacturers.

The cleaning cutter is not part of the scope of suppl.. Consult the manufacturer's spare parts list for the appropriate cleaning cutter: <https://spareparts.fronius.com/>

- 1 Remove the protective covering from the cleaning device

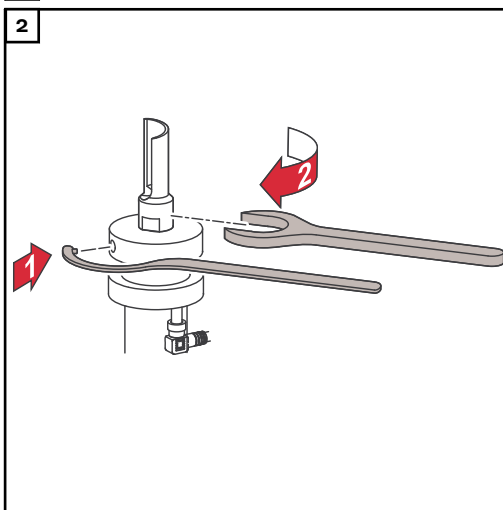

- 3 Fit the protective covering to the cleaning device in its original position

# Torch cleaning position

Cleaning position of the welding torch with externally routed coolant lines

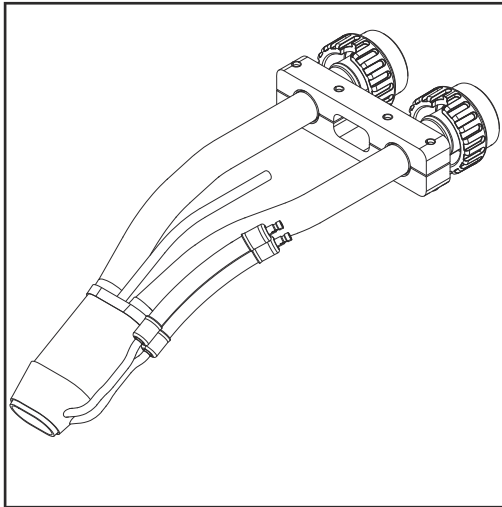

Welding torch with externally routed coolant lines

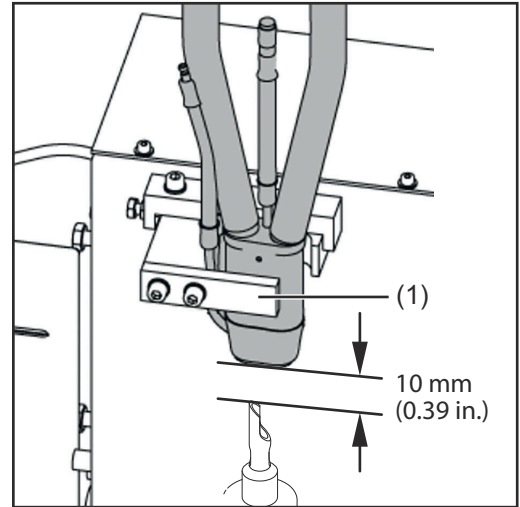

Cleaning position

## CAUTION!

### Danger due to incorrectly positioned welding torch!

This may damage the coolant lines on the welding torch.

- Ensure that the coolant lines on the gas nozzle cannot be damaged when the welding torch is moved into/out of the gas nozzle clamping device.

## NOTE!

The gas nozzle must sit on the inside of the holder (1).

Cleaning position of the welding torch with internally routed coolant lines

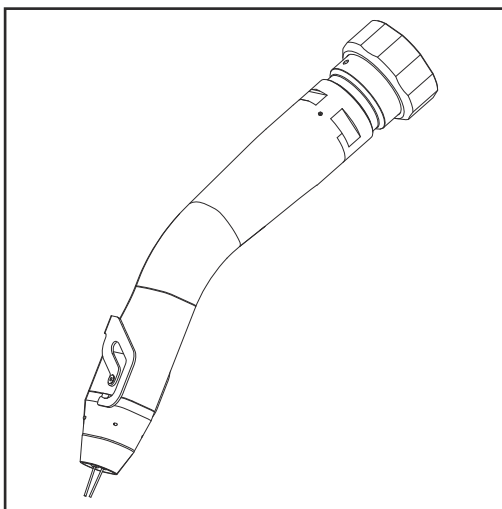

Welding torch with internally routed coolant lines

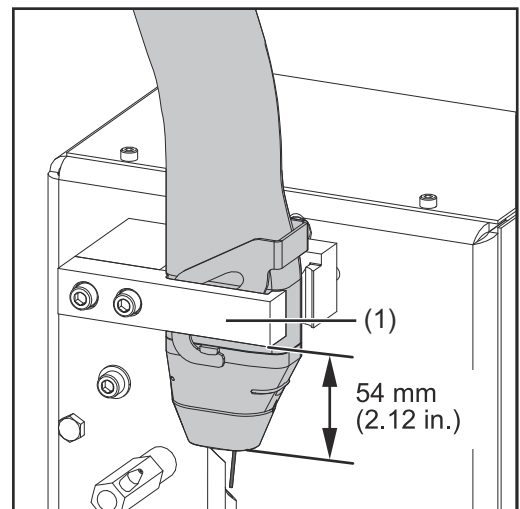

Cleaning position

## NOTE!

The gas nozzle must sit on the inside of the holder (1).

# Fitting the clamping system for welding torches with internally routed coolant lines

- Tools required**
- Torx® screwdriver, TX25
  - 3 mm & 5 mm Allen key

## Removing the existing clamping system



- 1 Undo the 5 Allen screws size 3 mm
- 2 Remove the housing cover

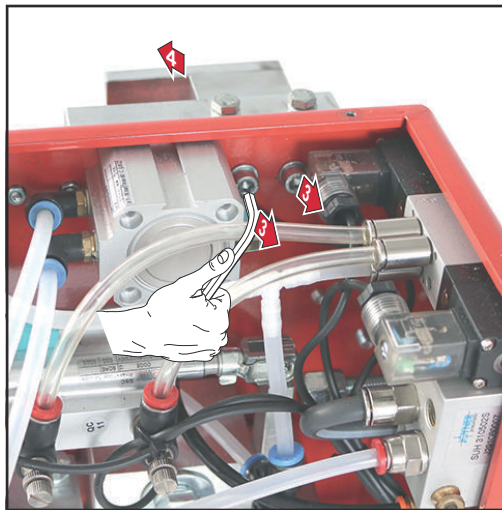

- 3 Undo the 2 Allen screws size 5 mm
- 4 Remove the 3-part clamping device element



- 5 Remove the Allen countersunk screw size 5 mm
- 6 Remove the clamping device element

### Fitting the Twin clamping system



- 1 Secure the clamping device element with the M8 x 25 mm Allen countersunk screw size 5 mm



- 2 Insert two 3 x 12 mm pins

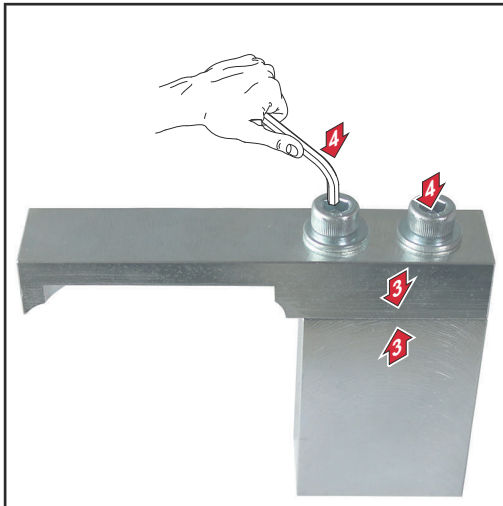

3 Assemble the clamping device elements

4 Screw together the clamping device elements with two washers and two M6 x 25 mm Allen screws size 5 mm

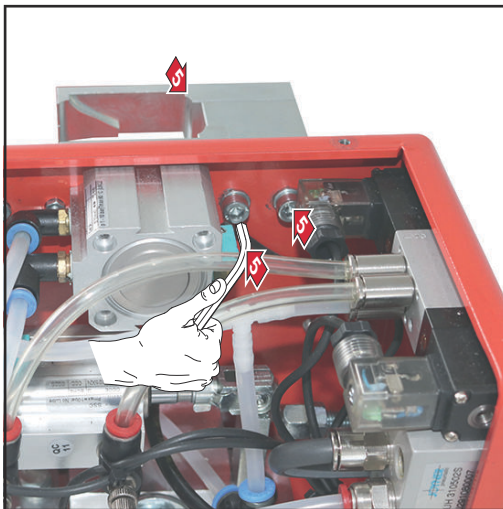

5 Fit the clamping device elements with two M6 x 16 mm Allen screws size 5 mm

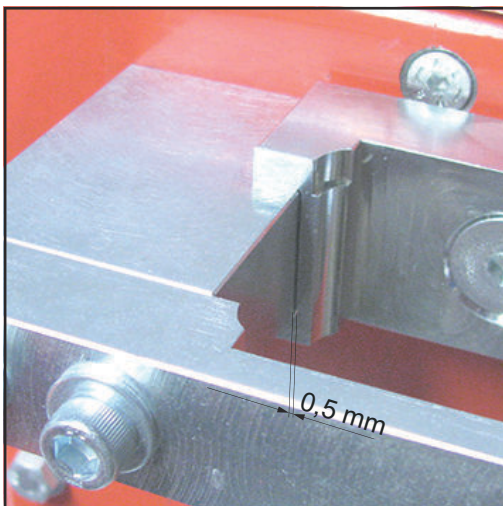

6 Make sure that there is a gap of approx. 0.5 mm between the clamping device elements.

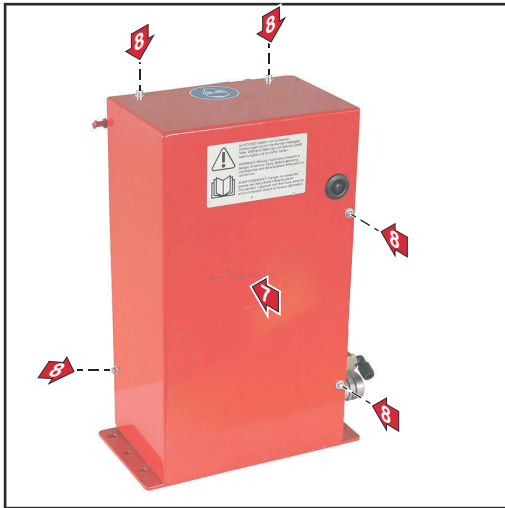

- 7** Fit the housing cover
- 8** Secure the housing cover with five M4 x 8 mm Allen screws size 3 mm



# Adjusting the lifting device

## Adjusting the lifting device

To make it easier to adjust the lifting device, it is advisable to fit one of the following adjustment aids to the torch body:

- Robacta Twin 500 adjustment aid, item no. 42,0001,5559
- Robacta Twin 900 adjustment aid, item no. 42,0001,5560

An adjustment aid is not necessary when the gas nozzle is open, as the welding torch is clamped above the gas nozzle. The gas nozzle can be removed beforehand. The bracket must be back in the starting position. When the gas nozzle is mounted, the bracket must be closed.

### NOTE!

**Ensure that the coolant lines on the gas nozzle cannot be damaged by the extending/retracting gas nozzle clamping device.**

- 1 Ensure that the lifting device is in its lowest lift position

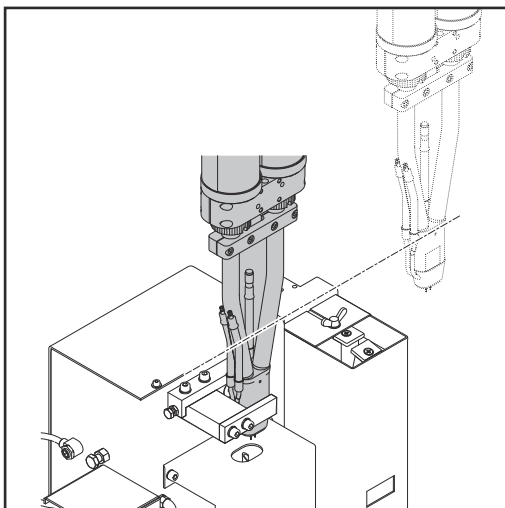

- 2 Move the welding torch to the cleaning position

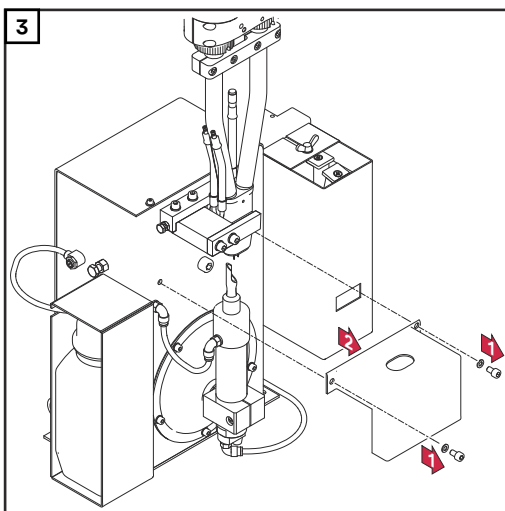

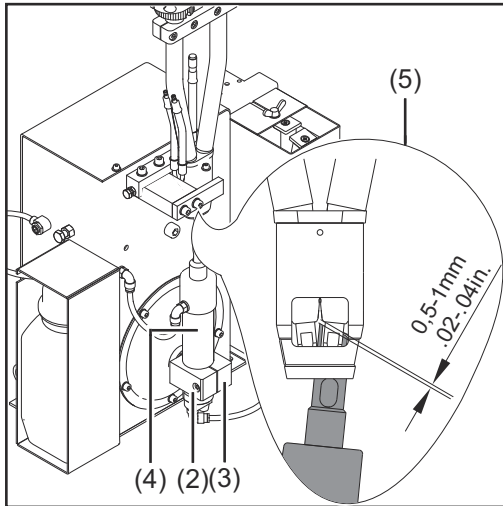

- 4 Loosen the Allen screw (2) on the lifting device
- 5 Push the lifting device (3) by hand into its highest lift position and hold in place
- 6 Push the cleaning motor (4) and cleaning cutter by hand into the cleaning position (5)

**NOTE!**

**The cleaning cutter must not touch any welding torch components.**

- 7 Fix the cleaning motor (4) in this position in the lifting device (3) - tighten the Allen screw (2) on the lifting device

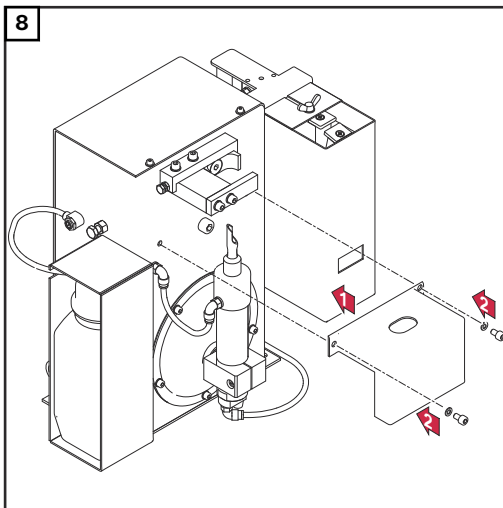

8

# Installing the compressed air supply

## Establishing the compressed air supply for the cleaning device, function of the compressed air relief valve

To establish the compressed air supply:

- 1 Depressurise the compressed air supply line of the cleaning device and ensure that it remains depressurised for the duration of the following work on the device
- 2 Screw the supplied compressed air relief valve into the compressed air connection on the cleaning device
- 3 Connect the compressed air supply line to the compressed air relief valve

The compressed air supply to the cleaning device can be broken and re-established by moving the compressed air relief valve forwards and backwards - see description below.

The diagram below shows the compressed air relief valve in the closed position = no compressed air supply to the device:

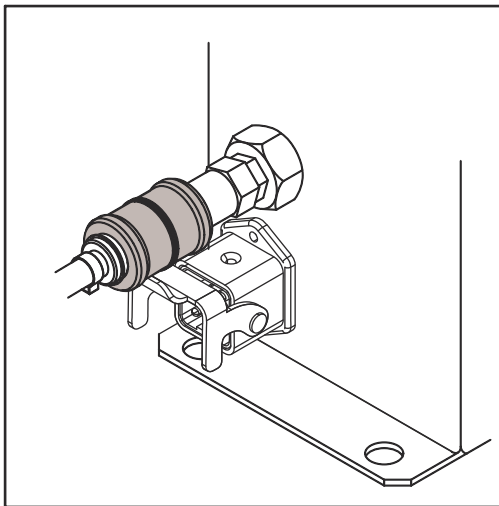

*Compressed air relief valve closed*

The diagram below shows the compressed air relief valve in the open position = compressed air is being supplied to the device:

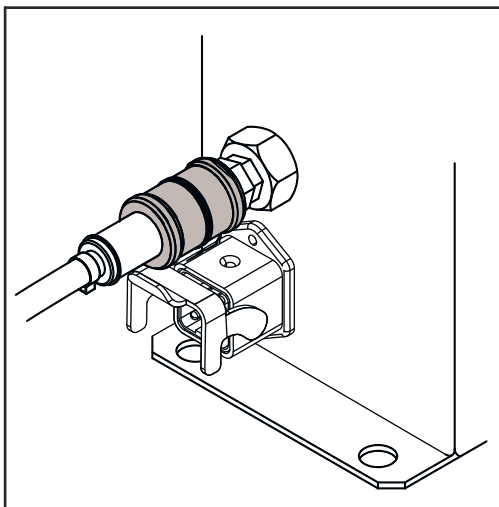

*Compressed air relief valve open*

# Starting up the parting agent nebuliser

Fill parting agent container (1 litre) and connect to the cleaning device

**NOTE!**

Only use "Robacta Reamer" parting agent (item number 42,0411,8042) supplied by the manufacturer.

The composition of the manufacturer's parting agent is designed specifically for the cleaning device. If other manufacturers' products are used, trouble-free operation cannot be guaranteed.

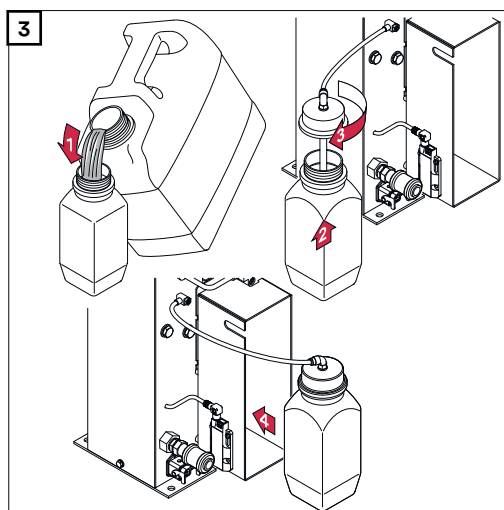
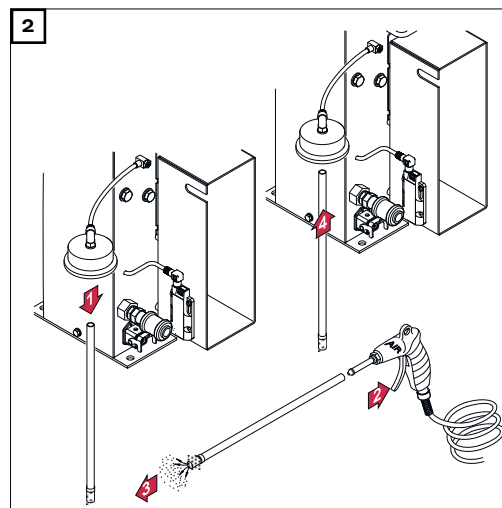
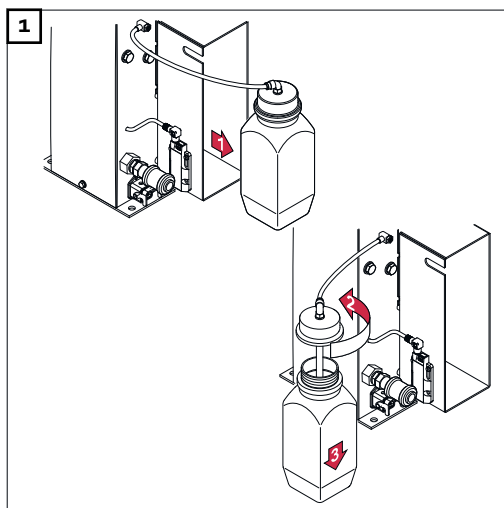

Connect the parting agent container (10 litres) to the cleaning device

**NOTE!**

Only use "Robacta Reamer" parting agent (item number 42,0411,8042) supplied by the manufacturer.

The composition of this parting agent is designed specifically for the cleaning device. If other manufacturers' products are used, trouble-free operation cannot be guaranteed.

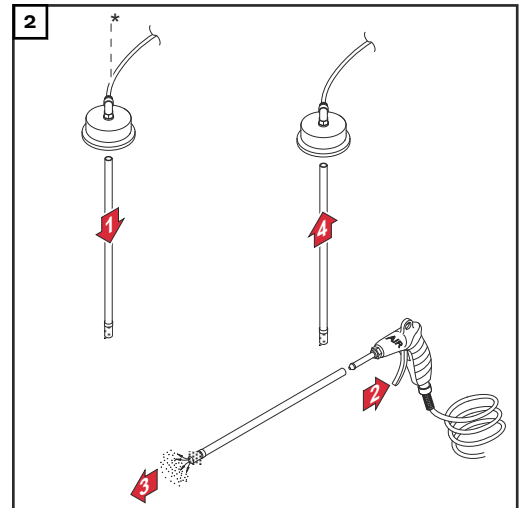
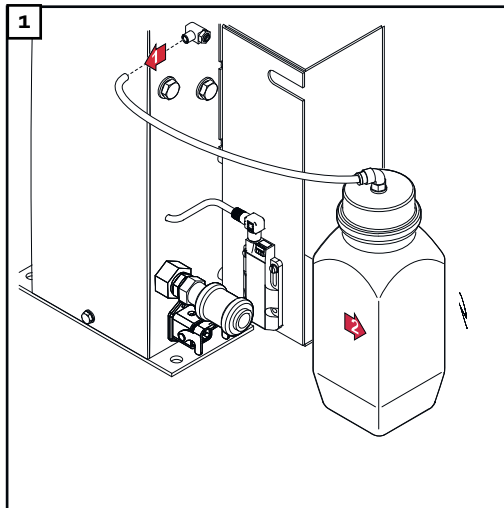

\* Option (long parting agent hose)

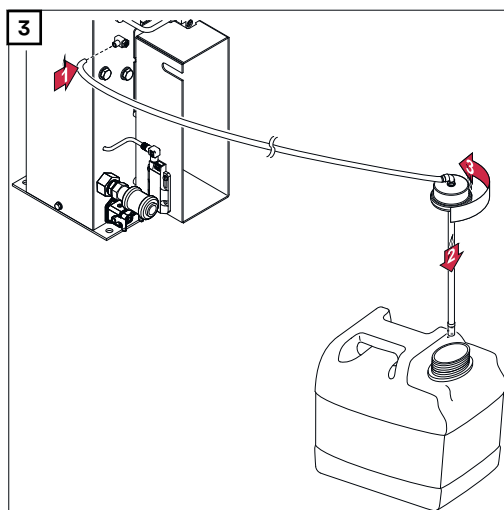

## Adjusting the parting agent nebuliser spray amount

### NOTE!

To ensure that the spray amount is adjusted properly, the welding torch must be in the cleaning position.

- 1 Establish a compressed air supply to the cleaning device
- 2 Connect the cleaning device to the robot control
- 3 Start the spraying process using the robot control and check that sufficient spray is being applied
- 4 If the spray amount is not sufficient, increase it as required
  - by adjusting the spray time using the robot control - a spray time of ~ 0.7 seconds is recommended (nur Robacta Reamer V only)
  - or by using the parting agent adjuster - see figure below

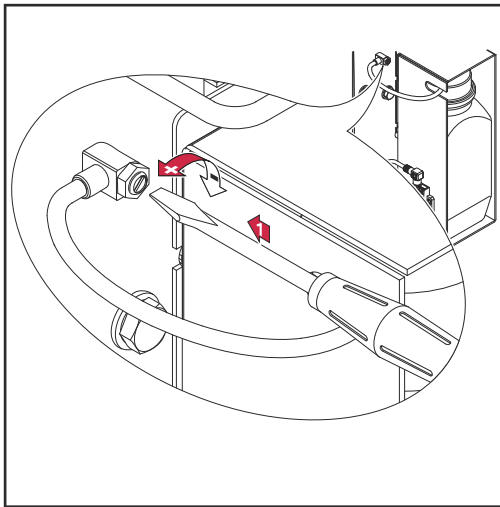

*Finely adjusting the spray amount on parting agent adjuster*

# Using the fill-level control sensor

## Optional fill-level control sensor

**NOTE!**

The fill-level control sensor is only available as an option.

The fill-level control sensor emits a signal once the fill level in the parting agent container falls below a specified level.

## Controls and indicators on the sensor

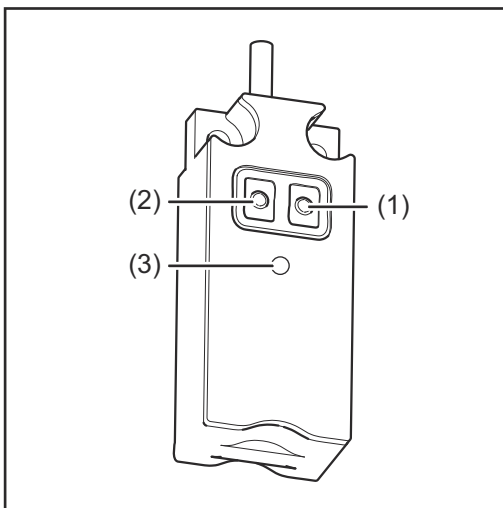

- (1) **'OUT OFF' button**  
for programming the sensor

---

- (2) **'OUT ON' button**  
for programming the sensor

---

- (3) **LED**  
indicates the sensor operating status
  - LED on/flashing: sensor is active
  - LED on/not flashing: sensor is not active

## Installation adapter borehole dimensions

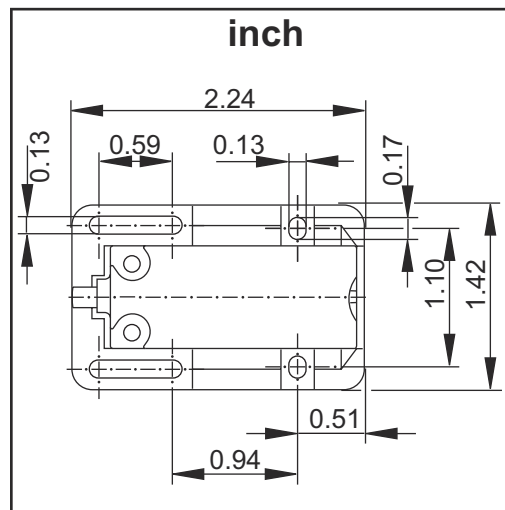
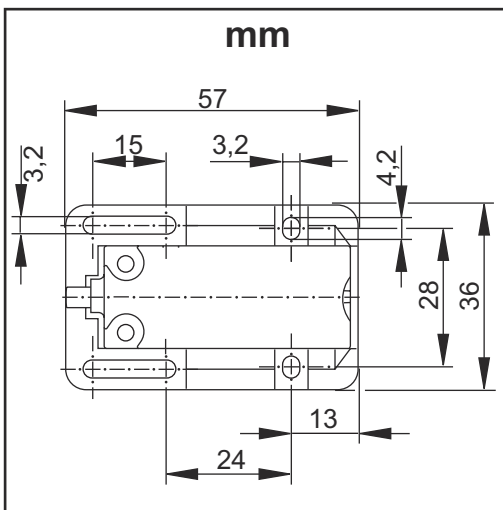

**Fitting the fill-level control sensor**

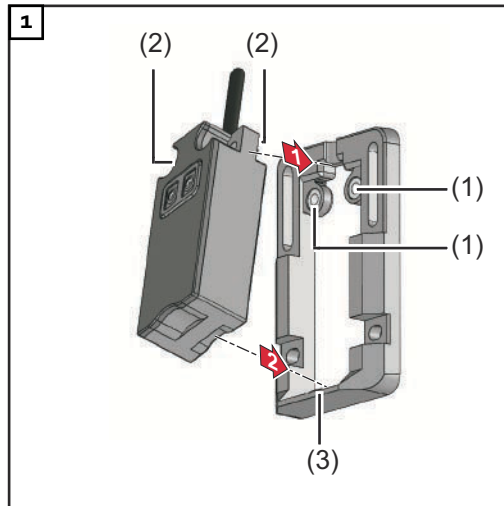

**NOTE!**

First press the upper part of the sensor into the installation adapter as shown - the sockets (1) on the installation adapter must fit into the recesses (2) in the sensor.

When the upper part of the sensor is properly lined up in the installation adapter, press the sensor fully into the installation adapter - the latch (3) on the installation adapter must snap back over the sensor (sensor audibly engages).

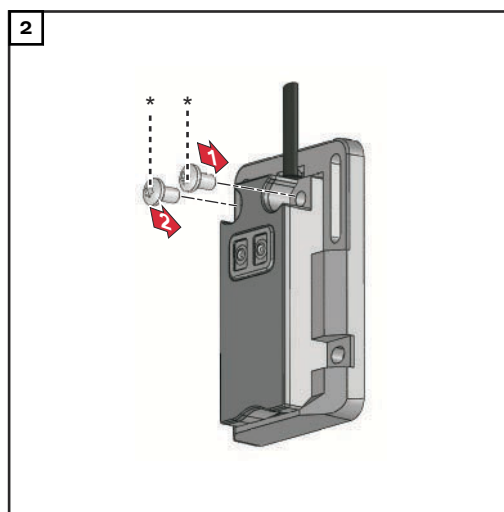

\* Use the fixings supplied with the sensor.

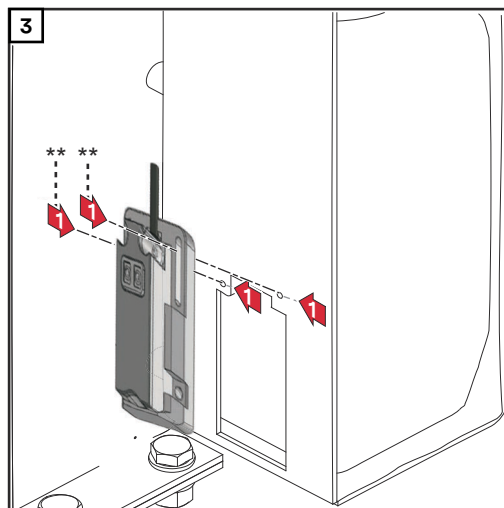

Screw the installation adapter and sensor on to the parting agent container housing

\*\* Fixings are not included in the sensor/installation adapter scope of supply. The installer is responsible for selecting the right type of fixing.

**NOTE!**

Ensure the fixings do not damage the parting agent container.



### Calibrating the empty state

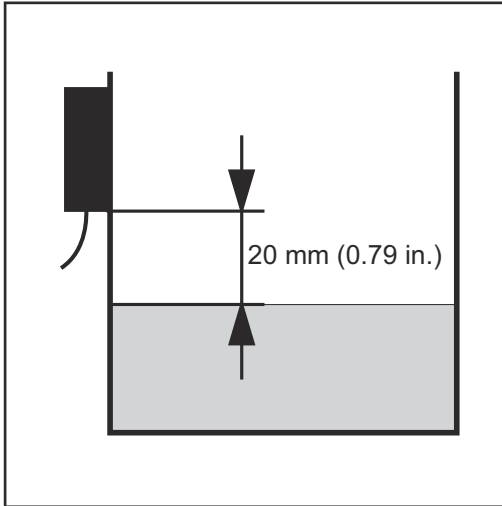

- 1 Drain the parting agent container until the parting agent level is at least 20 mm (0.787 in.) below the sensor
- 2 Establish a power supply to the sensor

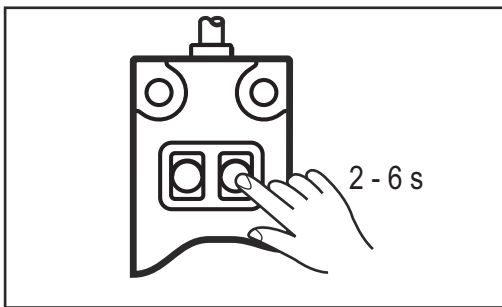

- 3 Press the "OUT OFF" button for between 2 and 6 seconds
  - The LED on the sensor flashes slowly
  - After releasing the "OUT OFF" button the LED goes out - the sensor has detected a low fluid level

### Calibrating the full state

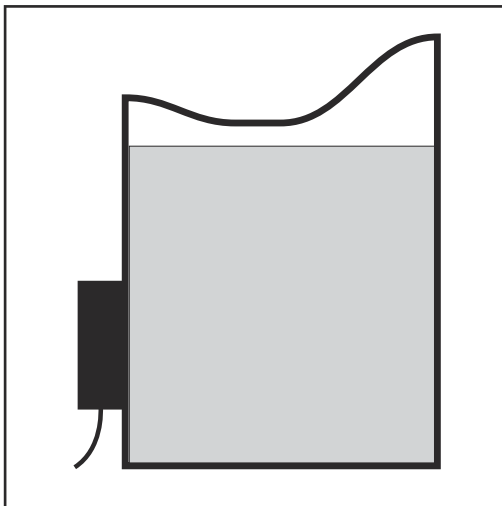

- 1 Fill the parting agent container with parting agent

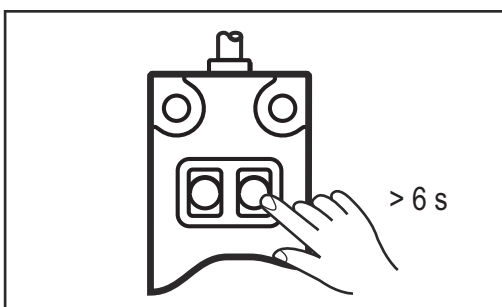

- 2 Press the "OUT OFF" button for at least 6 seconds
  - The sensor LED flashes slowly at first, then more rapidly after 6 seconds
  - After releasing the "OUT OFF" button the LED goes out - the sensor has detected a high fluid level

## Locking/unlocking the fill-level control sensor

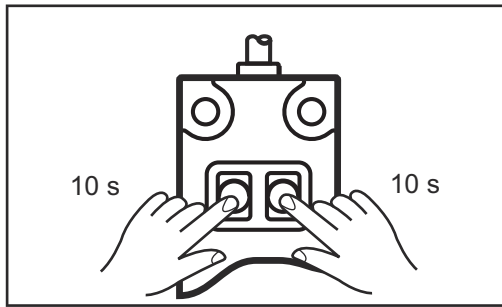

### NOTE!

It is possible to lock the fill-level control sensor to prevent it from being adjusted accidentally.

Locking the fill-level control sensor:

- 1 Simultaneously press the "OUT OFF" and "OUT ON" buttons for at least 10 seconds
  - The LED status changes briefly
    - if the LED lights up when locking, it will go out briefly after locking
    - if the LED does not light up when locking, it will come on briefly after locking

Unlocking the fill-level control sensor:

- 1 Simultaneously press the "OUT OFF" and "OUT ON" buttons for at least 10 seconds
  - The LED status changes briefly
    - if the LED lights up when unlocking, it will go out briefly after unlocking
    - if the LED does not light up when unlocking, it will come on briefly after unlocking

## Electrical connection

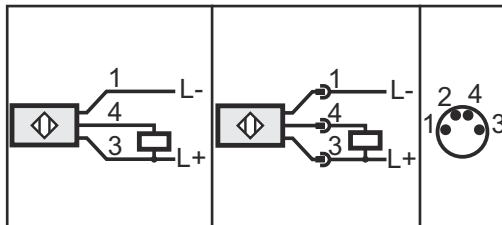

Wire colours:

1. brown
2. blue
3. blue
4. black

# Manually checking the cleaning device functions

## Safety

### **WARNING!**

For the following tasks, the cleaning device must be supplied with compressed air. This results in danger from the rotating cleaning cutter, cleaning motor moving up/down, gas nozzle clamping device moving out/in, flying parts (chips, etc.), compressed air/parting agent mixture escaping from the parting-agent injection nozzle.

This can result in serious injury and damage to property.

- ▶ Keep your body, especially your hands, face, hair, any objects and all clothing away from the cleaning cutter, cleaning motor, lifting device, gas nozzle clamping device, wire cutter and parting-agent injection nozzle..
- ▶ Wear ear protection!
- ▶ Wear protective goggles with side protection.

## Checking functions manually

### **NOTE!**

When the slot for the "Lifting device up/down", "Spray in parting agent" and "Clamp gas nozzle/Cleaning motor on" screws is positioned horizontally, function is deactivated.

- 1 Disconnect the cleaning device from the robot control
- 2 Establish a compressed air supply to the cleaning device

The following must be checked when the functions are being performed:

- function of the gas nozzle clamping device (gas nozzle clamping device extends/retracts)
- function of the cleaning motor (cleaning motor OFF/ON)

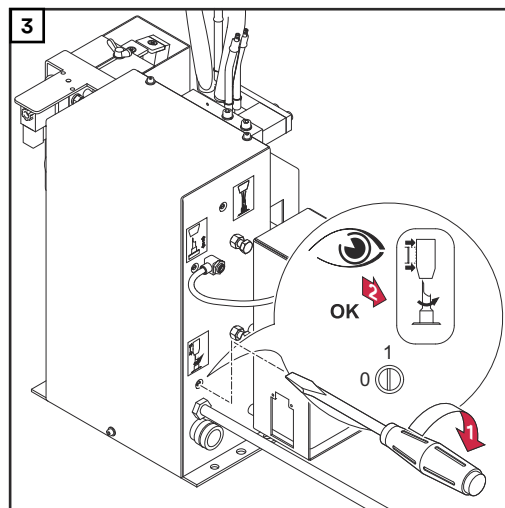

Clamp gas nozzle/cleaning motor on

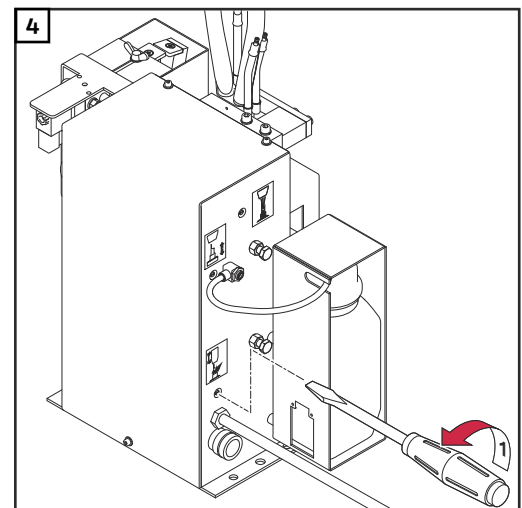

Deactivating the functions

The following must be checked when the function is being performed:

- how far the cleaning cutter is inserted in the gas nozzle (lifting device moves up/down)

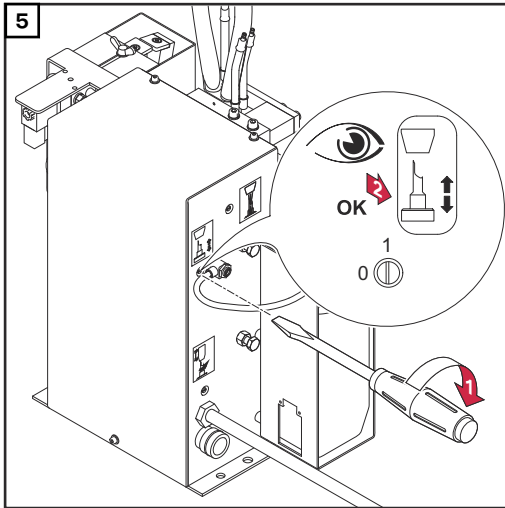

Lifting device up/down

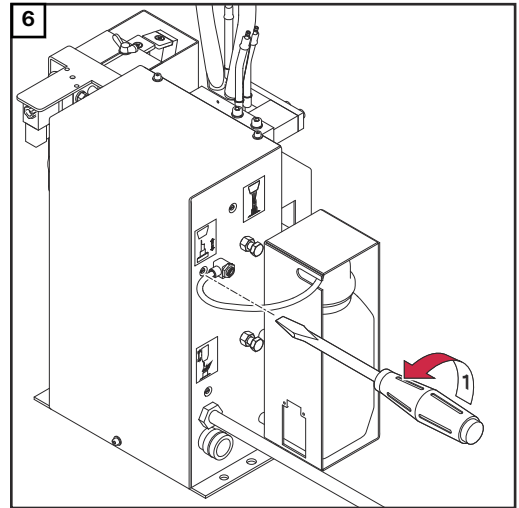

Deactivating the function

The following must be checked when the function is being performed:  
 - parting agent exit (parting agent is sprayed in)

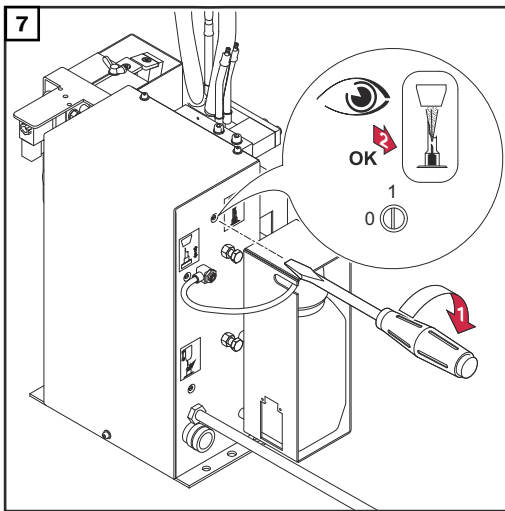

Spraying in parting agent

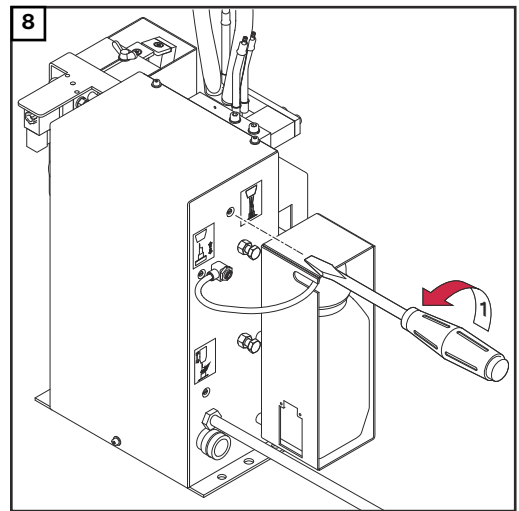

Deactivating the function

# Starting up the cleaning device

---

<b>Prerequisites for start-up</b>	<p>The following requirements must be met before the cleaning device is started up:</p> <ul style="list-style-type: none"><li>- Cleaning device is bolted to underlying surface</li><li>- Cleaning cutter is fitted</li><li>- Lifting device has been adjusted</li><li>- Parting agent nebuliser has been started up</li><li>- Compressed air supply has been established</li><li>- Functions have been checked manually</li><li>- Cleaning device connected to robot control</li></ul>
-----------------------------------	---

---

<b>Start-up</b>	<p>The cleaning device starts up when there is an active signal from the robot control.</p>
-----------------	---

# Cleaning programme

---

## Safety

### CAUTION!

#### **Danger due to improper installation and commissioning.**

This can result in damage to property.

- ▶ The cleaning device's functions must be manually checked before starting automatic operation.
  - ▶ Do not start in automated mode until the cleaning device has been properly installed and started up.
- 

### NOTE!

#### **Not coating the interior of the welding torch may result in permanent soiling of the torch when welding begins.**

- ▶ Always wet the interior of the welding torch with the manufacturer's parting agent before starting automatic operation.
-

**Cleaning program sequence - overview**

**NOTE!**

**Run through a complete cleaning process each time you start to weld.**

The cleaning program sequence is composed of the following sub-processes:

1. Wire cutter - pos. A
2. "Parting agent level" query (option)
3. "Cleaning motor lowered" query
4. "Gas nozzle free" query
5. Cleaning - pos. B

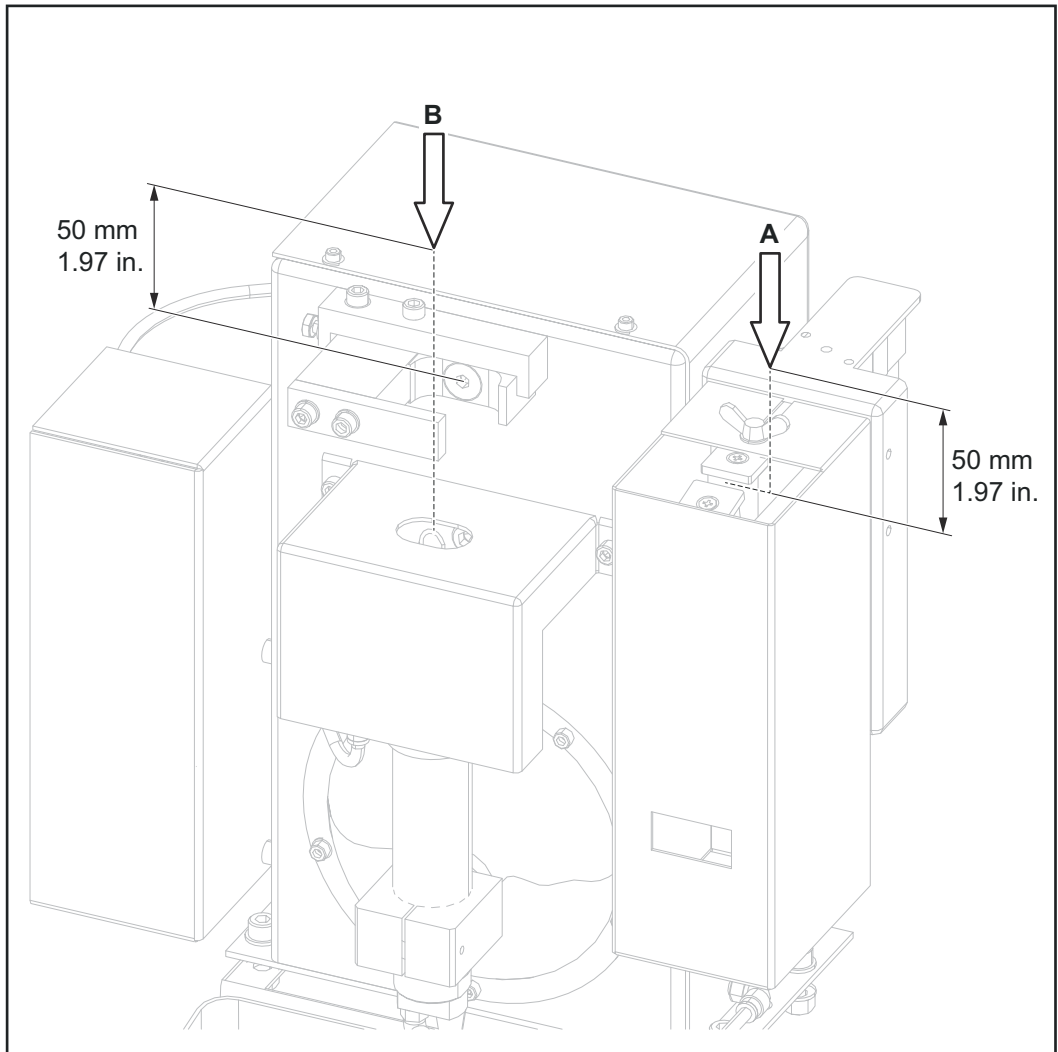

Pos. A = wire cutter, pos. B = cleaning

## 1. Wire cutter

### NOTE!

Perform a complete cleaning cycle each time you start to weld.

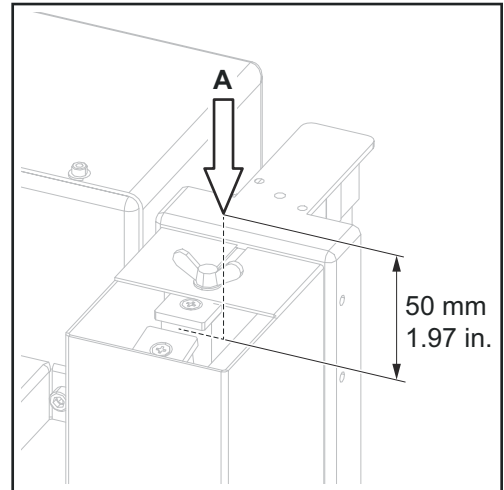
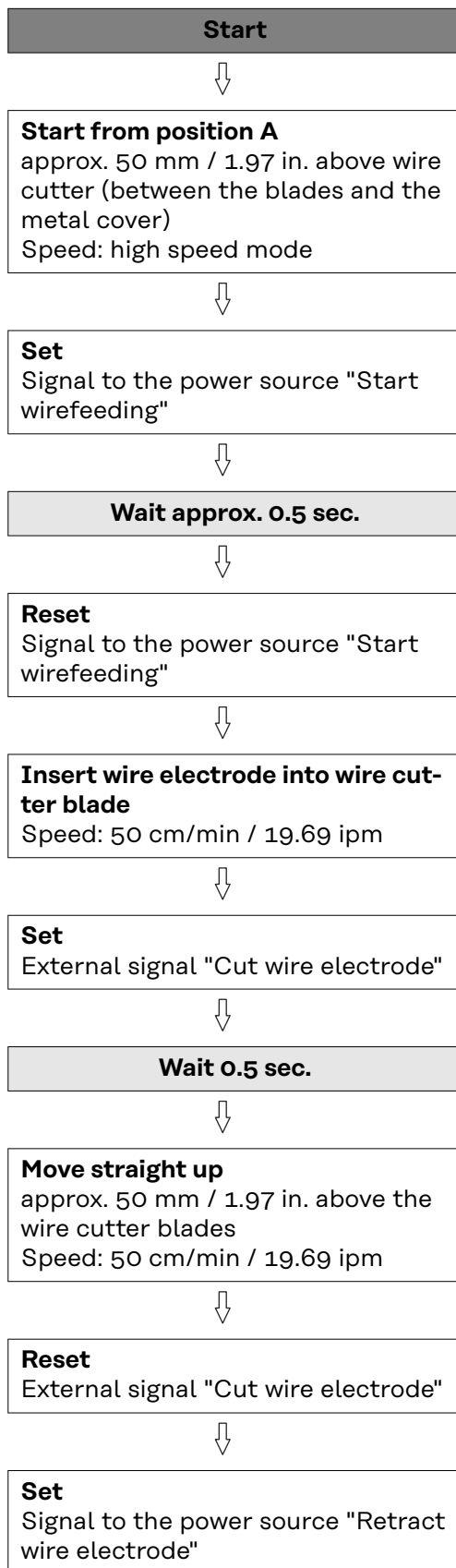



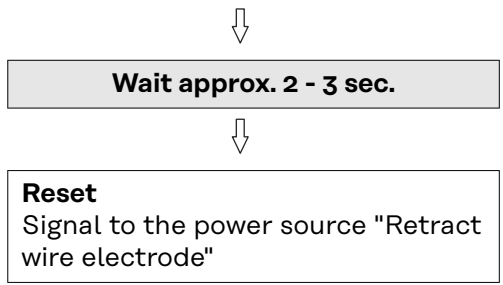

Next program step:  
2. "Parting agent level" query (option)

2. "Parting agent level" query (option)

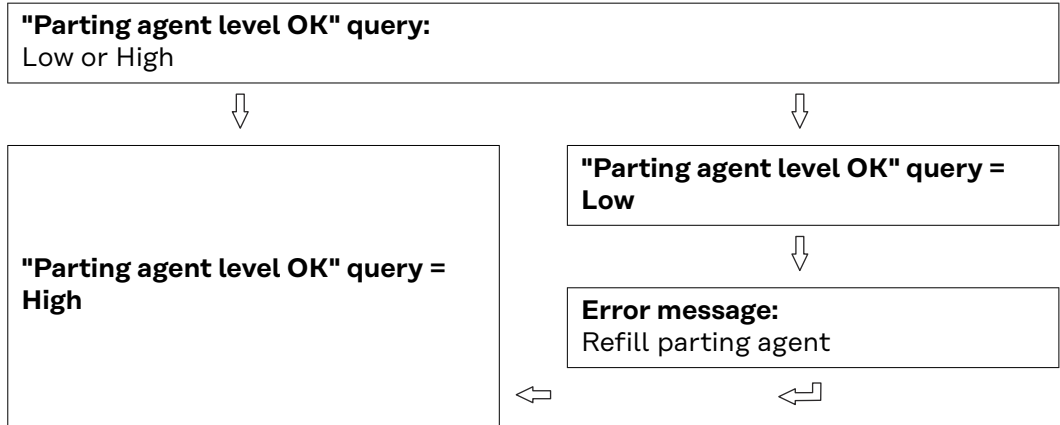

Next program step:  
3. "Cleaning motor lowered" query

3. "Cleaning motor lowered" query

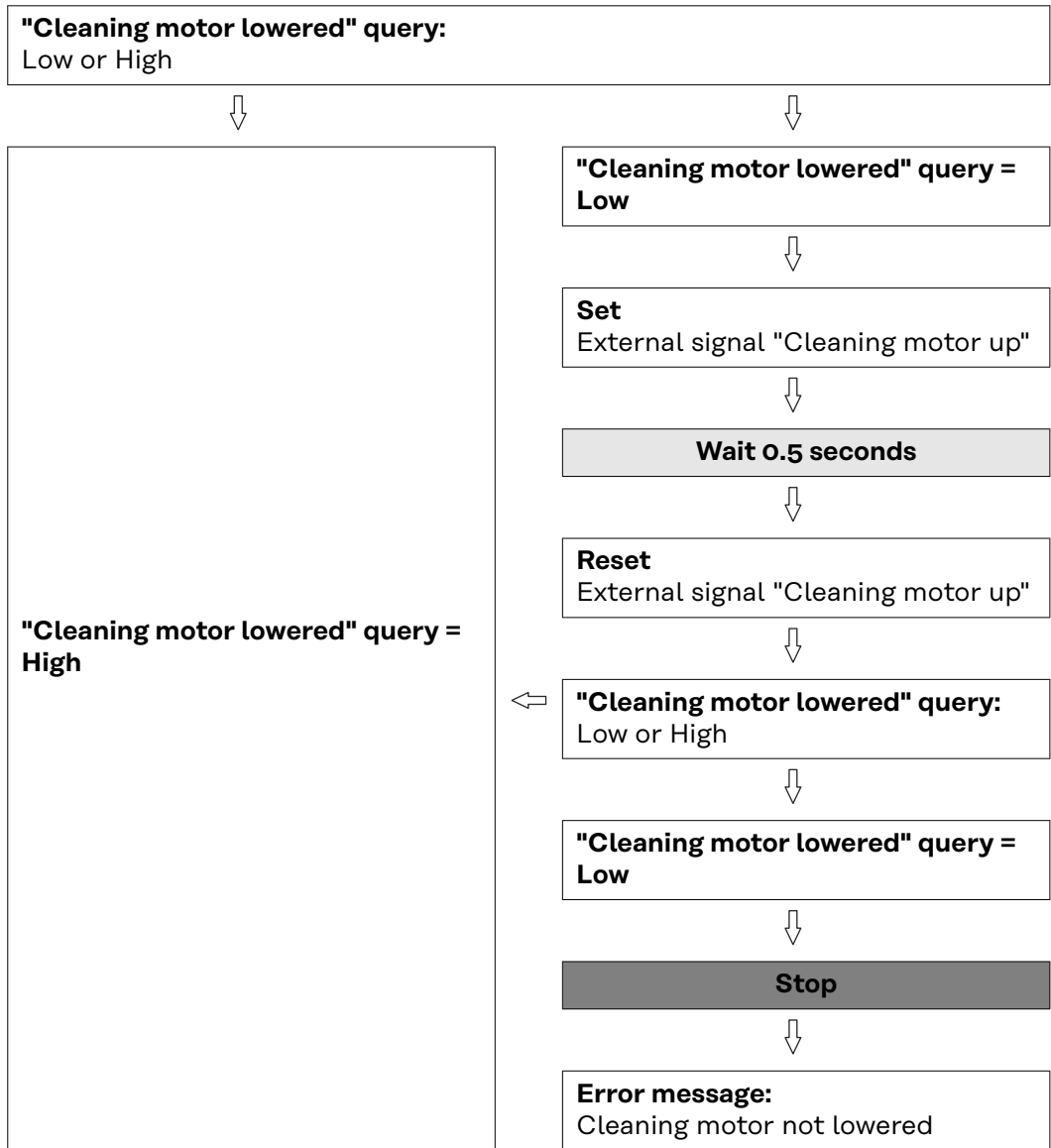

Next program step:  
4. "Gas nozzle free" query

4. "Gas nozzle free" query

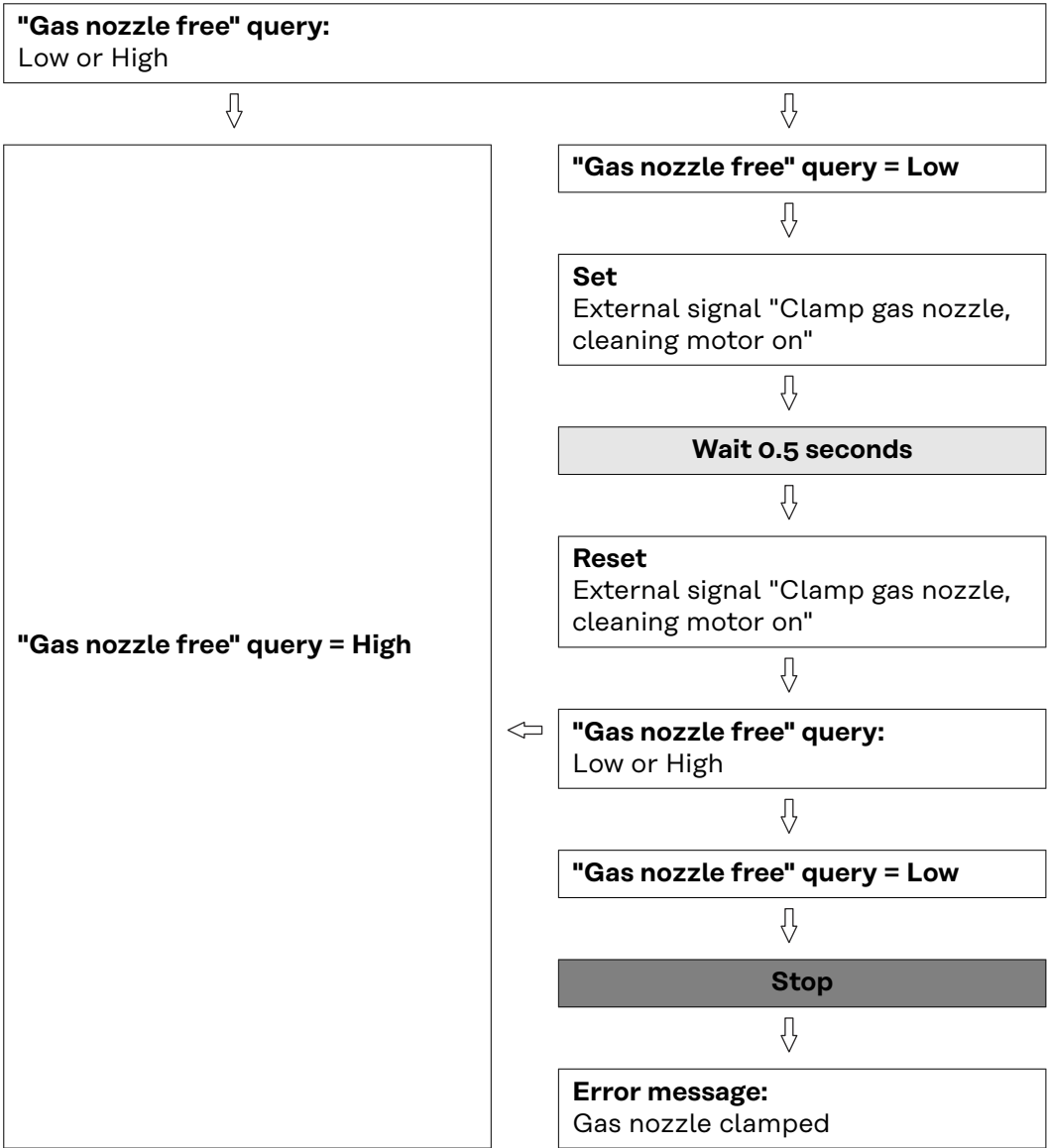

Next program step:  
5. Cleaning

## 5. Cleaning

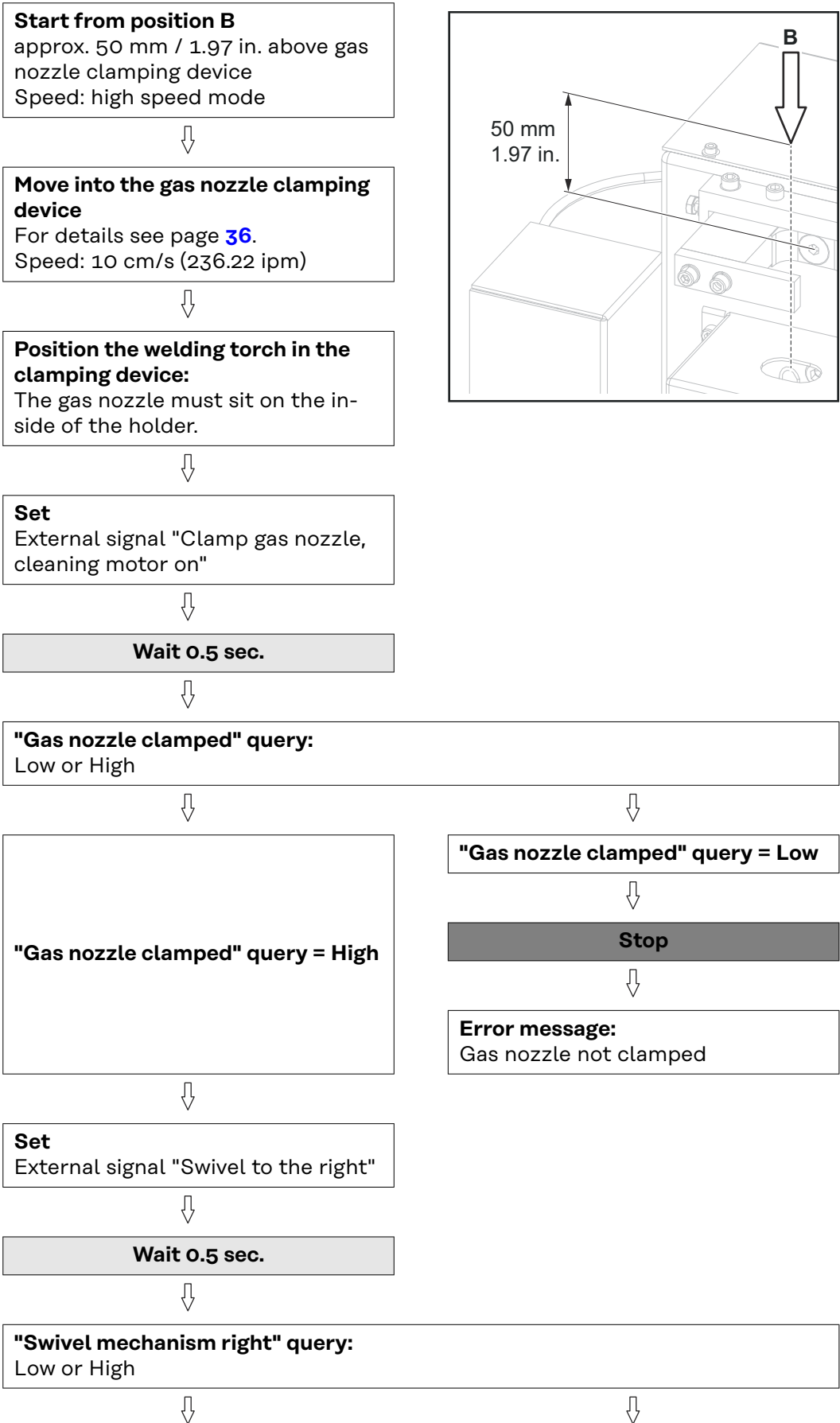

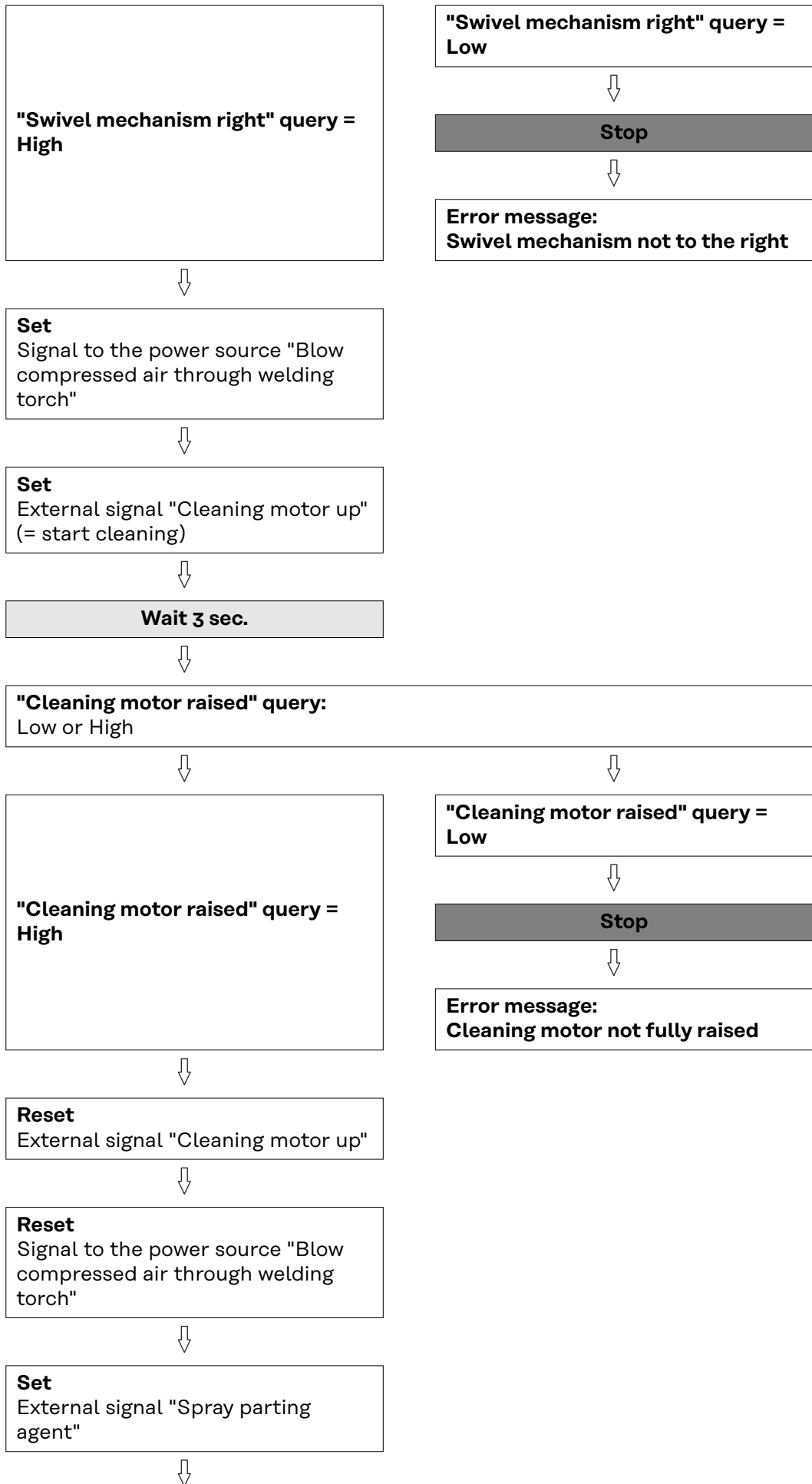

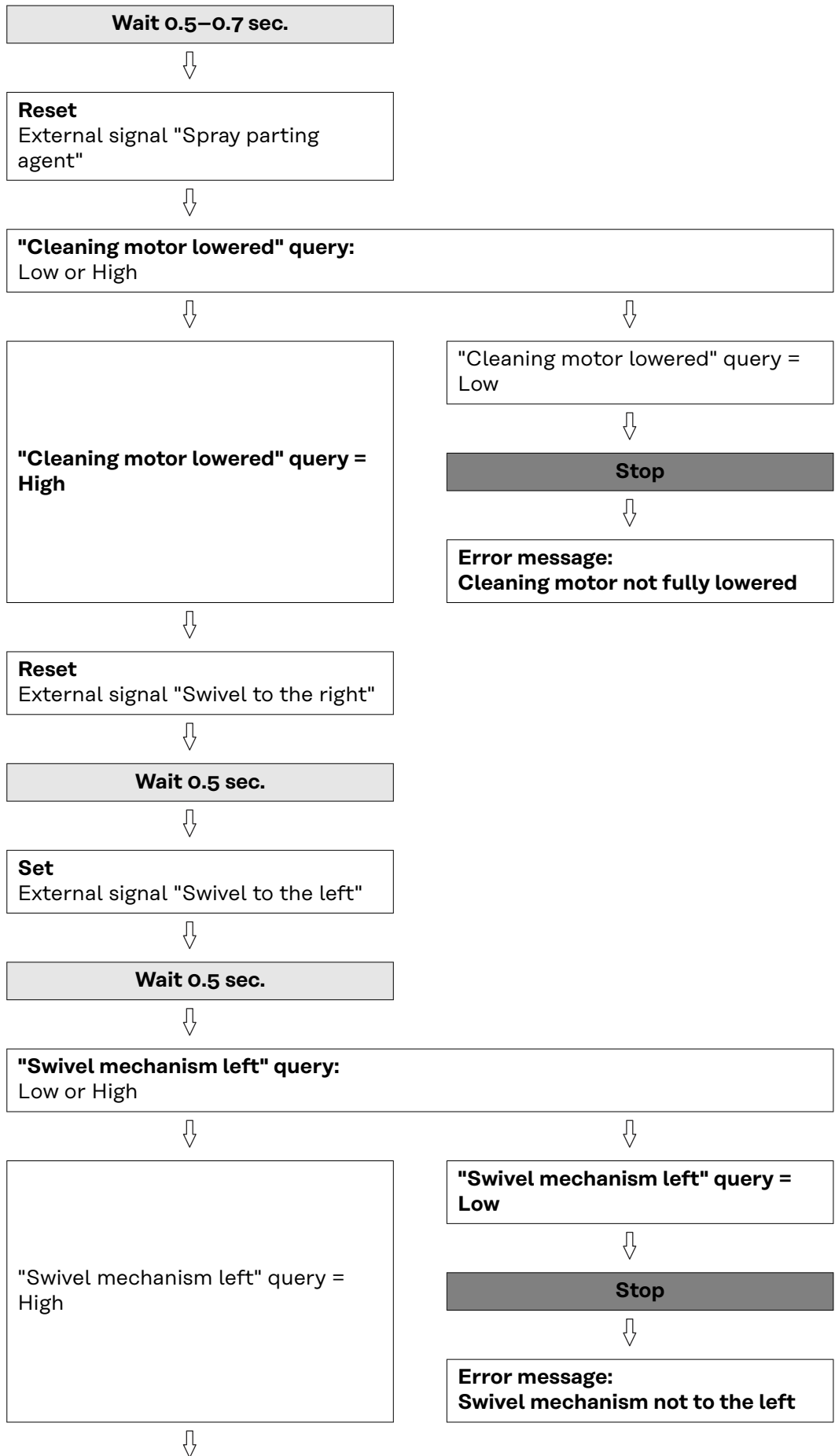

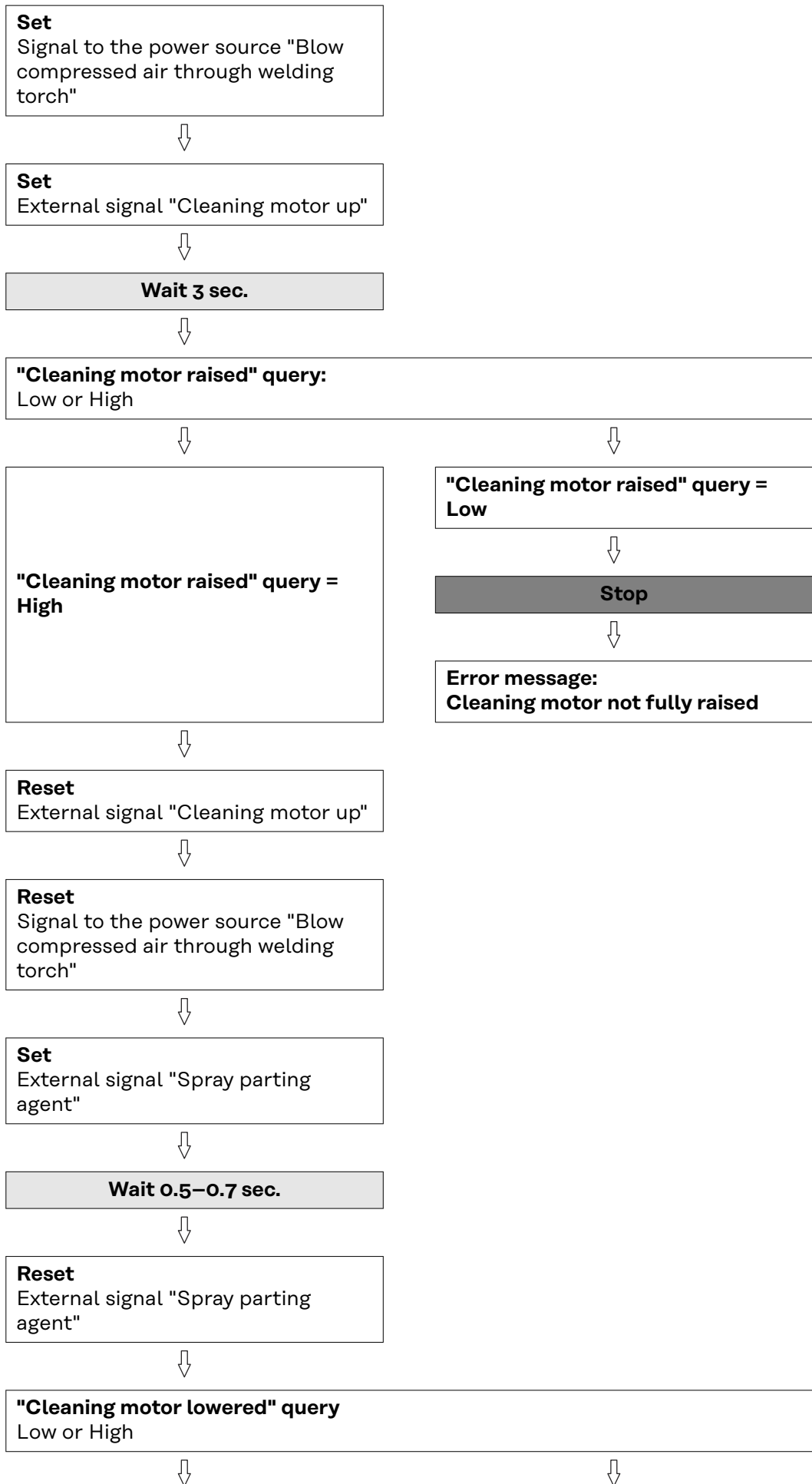

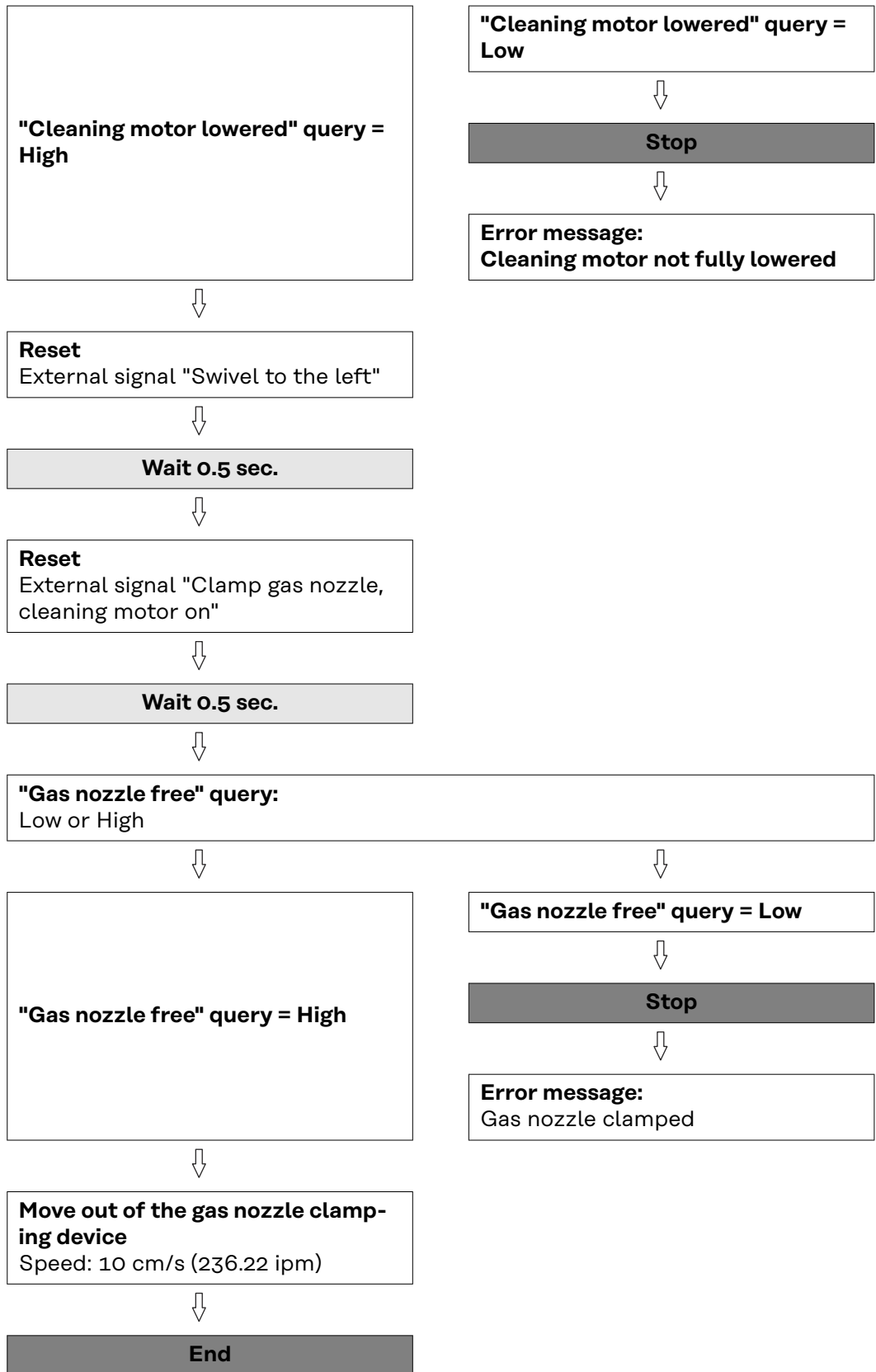



# Signal waveform for cleaning

## Signal inputs

1. Gas nozzle clamped:
2. Move swivel mechanism to the right:
3. Move swivel mechanism to the left:
4. Cleaning motor up:
5. Spray parting agent:

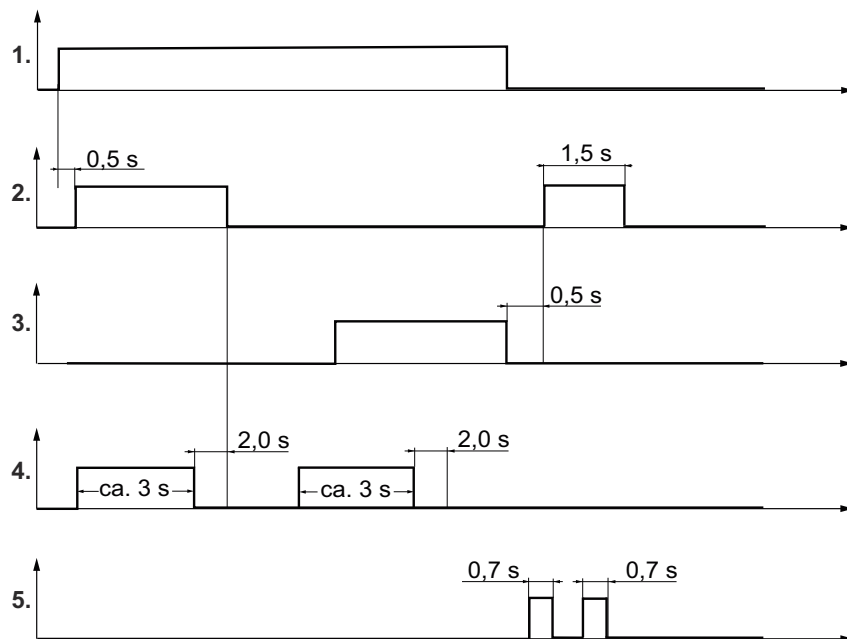

## Signal outputs

Gas nozzle free:



Gas nozzle clamped:

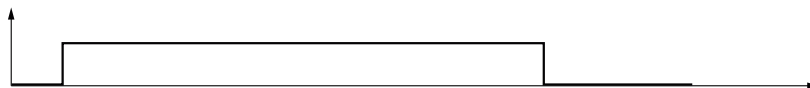

Cleaning motor lowered:



Cleaning motor raised:

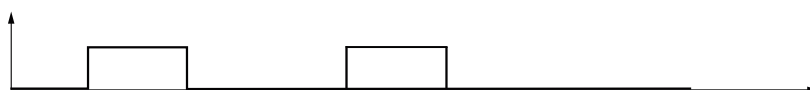

Swivel mechanism right:



Swivel mechanism left:

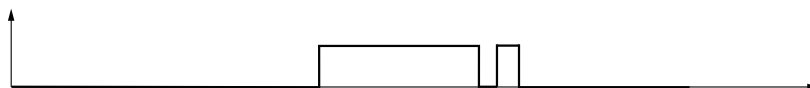

---

**Signals not defined using time**

Parting agent level OK:

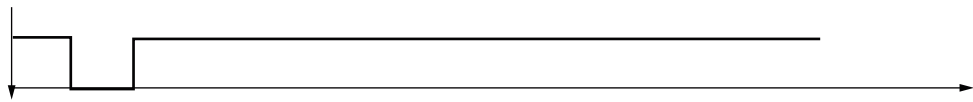

---

**Signal waveform: wire cutter (inputs and outputs)**

Cut wire electrode input signal:



# **Care, maintenance and disposal**



## Safety

Observe the following safety rules for all work described in the "Care, maintenance and disposal" section.

### **WARNING!**

#### **Danger due to incorrect operation and incorrectly performed work.**

This can result in serious injury and damage to property.

- ▶ All activities described in these Operating Instructions may only be carried out by trained and qualified personnel.
- ▶ All functions described in these Operating Instructions may only be used by trained and qualified personnel.
- ▶ Do not carry out any of the work or use any of the functions described until you have fully read and understood the following documents: these Operating Instructions, all the Operating Instructions for the system components, especially the safety rules.

### **WARNING!**

#### **Risk of machines starting automatically!**

This can result in serious injury and damage to property.

- ▶ In addition to these Operating Instructions, also observe the safety rules issued by the manufacturer of the robot and welding system.
- ▶ Ensure that all protective measures have been taken and will remain in place while you are in the working area of the robot.

### **WARNING!**

#### **Danger from mechanically powered parts, flying parts (shavings, etc.) and compressed air/parting agent mixture escaping from the parting-agent injection nozzle.**

This can result in severe injuries.

- ▶ Before carrying out any work on the cleaning device or the connected system components, disconnect the customer's compressed air and power supplies from the cleaning device and the connected system components, and ensure that they remain disconnected until all work is complete.

**IMPORTANT!** Observe the "Ensuring that the cleaning device is depressurised" section - see page [30](#).



## **WARNING!**

### **Danger from power supply and/or compressed air supply to the cleaning device!**

The following conditions can lead to serious injuries:

rotating cleaning cutters

lifting device moving up/down

extending/retracting gas nozzle clamping device

activated wire cutter

flying parts (shavings, etc.)

compressed air/parting agent mixture escaping from the parting-agent injection nozzle

If work has to be performed on the cleaning device while it is being supplied with voltage and/or compressed air:

- ▶ keep your body, especially your hands, face, hair, any objects and all clothing away from the cleaning cutter, lifting device, gas nozzle clamping device, wire cutter and parting-agent injection nozzle
  - ▶ Wear ear protection
  - ▶ Wear protective goggles with side protection
- 



## **CAUTION!**

### **Danger due to cleaning cutter that has become very hot through use.**

This can cause burns.

- ▶ Before handling cleaning cutters, allow cleaning cutter to cool to room temperature (+25 °C, +77 °F).
-

# Care, maintenance and disposal

## General

The cleaning device generally needs no maintenance. However, to keep the cleaning device in good working condition for years to come, several points on care and maintenance must be observed.

## Before each start-up

- Check fill level in parting agent container and top up if necessary
- Check fill level in parting agent spatter tray and empty if necessary
- Check cleaning cutter for wear and replace if necessary
- Empty the cleaning device spatter tray
- If fitted, empty the wire cutter tray
- Carry out a general visual inspection of the cleaning device and make sure that any damage is repaired immediately (before start-up)

## Daily

 **CAUTION!**

**Danger from cleaning agents containing solvents.**

This can result in damage to property.

- ▶ Only use solvent-free cleaning products on the cleaning device.

- 1 Remove parting agent deposits and dirt from device

## Weekly

 **CAUTION!**

**Danger from cleaning agents containing solvents.**

This can result in damage to property.

- ▶ Only use solvent-free cleaning products on the parting agent container.

- 1 Check the parting agent container for soiling and clean if necessary
- 2 Blow through suction filter in parting agent container using compressed air from the inside outwards through the suction hose (for more detailed information see section [Starting up the parting agent nebuliser](#) from page 44)

## Every 6 months

- 1 Open the device and check the pneumatic valves for
  - Leaks
  - The secure seating of all screws
  - The secure seating of all screw joints on the pneumatic valves

## As necessary

Open the device and

- 1 Clean inside of device using dry reduced compressed air
- 2 Lightly oil the lifting device cylinder guides
- 3 Restore the original condition of the device

---

**Disposal**

Dispose of in accordance with the applicable national and local regulations.



# Adjust the swivel mechanism stop angle

## General

To make it easier to adjust the stop angle, it is advisable to fit one of the following adjustment aids to the torch neck:

- Robacta Twin 500 adjustment aid, item no. 42,0001,5559
- Robacta Twin 900 adjustment aid, item no. 42,0001,5560

## Preparatory work

- 1 Move the welding torch to the cleaning position

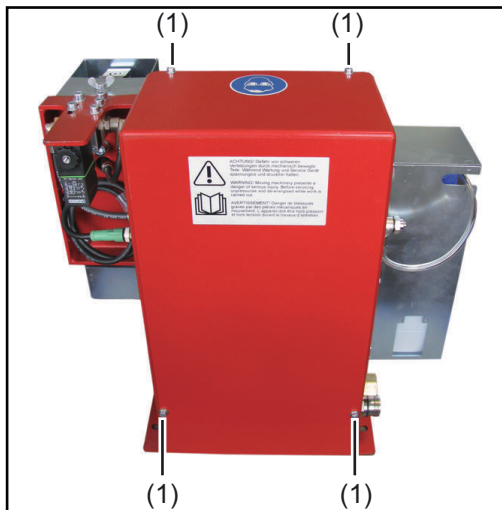
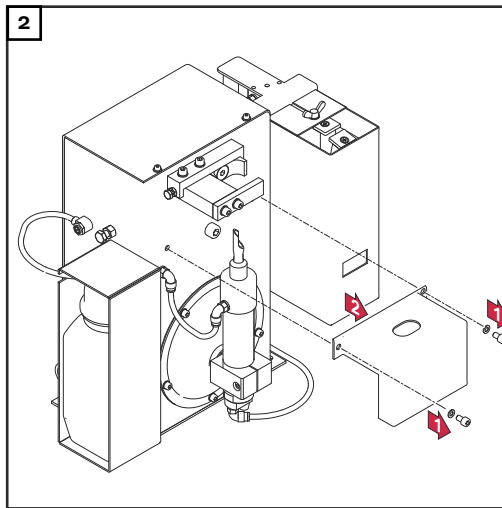

- 3 Undo the four Allen screws (1)
- 4 Remove cleaning device housing cover

**Adjust the swivel mechanism stop angle**

- Banking screw (4) adjusts the left stop angle
- Banking screw (5) adjusts the right stop angle

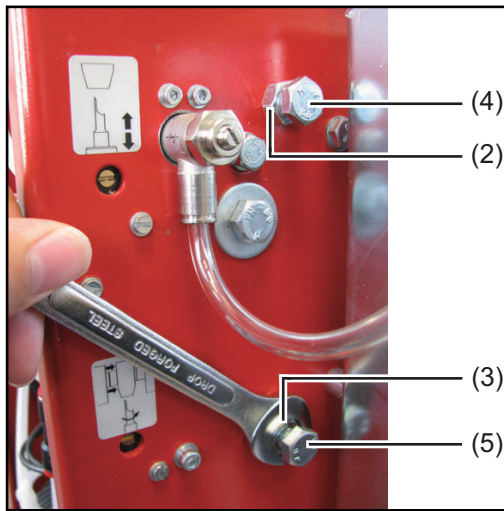

- 1** Undo nut (2) or (3) depending on the stop angle to be adjusted
- 2** Depending on the stop angle to be adjusted, undo banking screw (4) or (5) until the cleaning motor can be moved to the highest position where it is not in contact with the welding torch parts

- 3** Manually tilt the cleaning motor to the side to be adjusted and move to the highest position
- 4** Adjust the respective banking screw so that the cleaning cutter cannot collide with a contact tip or a gas nozzle
- 5** Return the cleaning motor to the lowest position
- 6** Secure the banking screw using the nut (2) or (3) undone previously

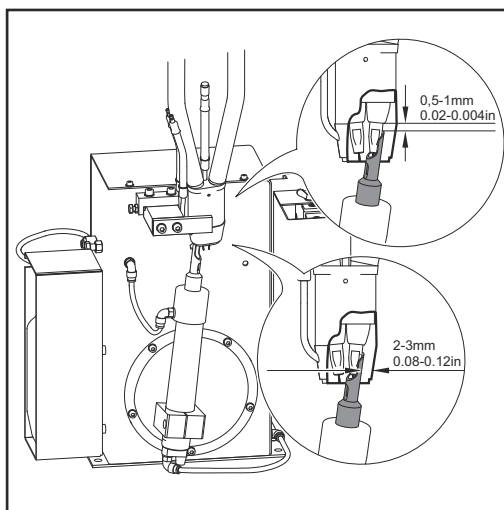

- 7** Manually move the cleaning motor to the highest position
- 8** Manually tilt the cleaning motor to the left and right
  - the cleaning cutter must not collide with the contact tips or gas nozzle
- 9** If the cleaning cutter touches welding torch components, adjust the stop angle again

And finally...

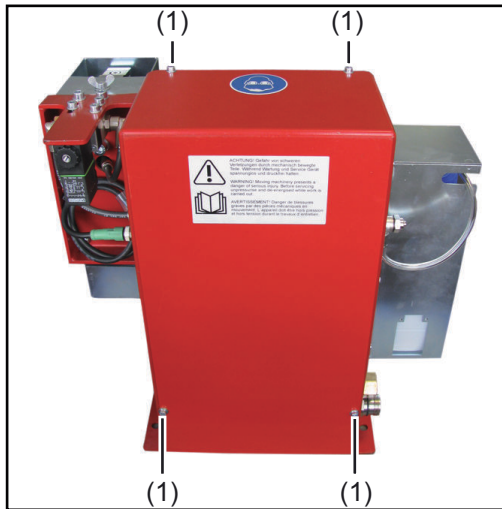

- 1 Screw on the cleaning device housing cover using the four original screws and washers (1)

EN

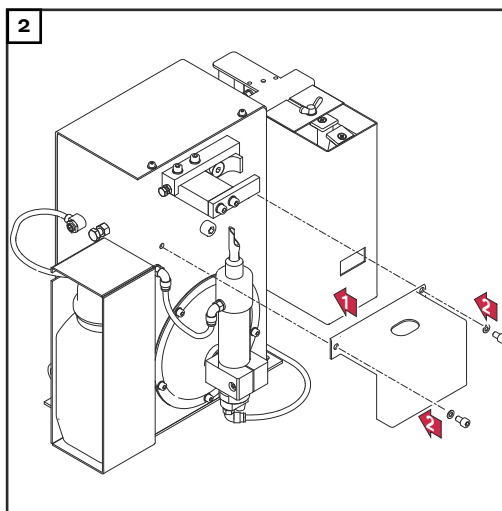



# Troubleshooting



## Safety

Observe the following safety rules for all work described in the "Troubleshooting" section.

### **WARNING!**

#### **Danger due to incorrect operation and incorrectly performed work.**

This can result in serious injury and damage to property.

- ▶ All activities described in these Operating Instructions may only be carried out by trained and qualified personnel.
- ▶ All functions described in these Operating Instructions may only be used by trained and qualified personnel.
- ▶ Do not carry out any of the work or use any of the functions described until you have fully read and understood the following documents:  
these Operating Instructions,  
all the Operating Instructions for the system components, especially the safety rules.

### **WARNING!**

#### **Risk of machines starting automatically!**

This can result in serious injury and damage to property.

- ▶ In addition to these Operating Instructions, also observe the safety rules issued by the manufacturer of the robot and welding system.
- ▶ Ensure that all protective measures have been taken and will remain in place while you are in the working area of the robot.

### **WARNING!**

#### **Danger from mechanically powered parts, flying parts (shavings, etc.) and compressed air/parting agent mixture escaping from the parting-agent injection nozzle.**

This can result in severe injuries.

- ▶ Before carrying out any work on the cleaning device or the connected system components, disconnect the customer's compressed air and power supplies from the cleaning device and the connected system components, and ensure that they remain disconnected until all work is complete.

**IMPORTANT!** Observe the "Ensuring that the cleaning device is depressurised" section - see page [30](#).



## **WARNING!**

### **Danger from power supply and/or compressed air supply to the cleaning device!**

The following conditions can lead to serious injuries:

rotating cleaning cutters

lifting device moving up/down

extending/retracting gas nozzle clamping device

activated wire cutter

flying parts (shavings, etc.)

compressed air/parting agent mixture escaping from the parting-agent injection nozzle

If work has to be performed on the cleaning device while it is being supplied with voltage and/or compressed air:

- ▶ keep your body, especially your hands, face, hair, any objects and all clothing away from the cleaning cutter, lifting device, gas nozzle clamping device, wire cutter and parting-agent injection nozzle
  - ▶ Wear ear protection
  - ▶ Wear protective goggles with side protection
- 



## **CAUTION!**

### **Danger due to cleaning cutter that has become very hot through use.**

This can cause burns.

- ▶ Before handling cleaning cutters, allow cleaning cutter to cool to room temperature (+25 °C, +77 °F).
-



## Errors in program sequence

---

### The parting agent does not spray

Parting agent container is full

Cause: Not enough spray

Remedy: Adjust spray time

Cause: Parting agent hose suction filter in the parting agent container is soiled

Remedy: Clean the suction filter of the parting agent hose with compressed air (for more detailed information, see section [Starting up the parting agent nebuliser](#) from page 44)

Cause: No signal from robot

Remedy: Check robot program

Cause: Parting-agent injection nozzle blocked

Remedy: Clean parting-agent injection nozzle  
Contact After-Sales Service (arrange for parting-agent injection nozzle to be replaced)

Cause: Vacuum pump faulty

Remedy: Contact After-Sales Service (arrange for vacuum pump to be replaced)

Cause: Mechanical fault on solenoid valve

Remedy: Contact After-Sales Service (arrange for solenoid valve to be replaced)

---

### Welding torch is poorly cleaned or damaged

Cause: Lifting device not adjusted properly

Remedy: Adjust the lifting device

Cause: Cleaning cutter not suited to welding torch shape

Remedy: Fit the correct cleaning cutter

Cause: Cleaning cutter is worn

Remedy: Replace cleaning cutter

---

**Cleaning cutter collides with a contact tip or gas nozzle**

Cause: Lifting device not adjusted properly

Remedy: Adjust the lifting device

Cause: Cleaning cutter not suited to welding torch shape

Remedy: Fit the correct cleaning cutter

Cause: Cleaning cutter is worn

Remedy: Replace cleaning cutter

Cause: Incorrect swivel mechanism stop angle

Remedy: Adjust the swivel mechanism stop angle

---

**Lifting device is not moving up or down**

Cause: No compressed air supply

Remedy: Establish a compressed air supply

Cause: No signal from robot

Remedy: Check robot program

Cause: Mechanical fault on solenoid valve

Remedy: Contact After-Sales Service (arrange for solenoid valve to be replaced)

Cause: Choke valve not adjustable, or faulty

Remedy: Contact After-Sales Service (arrange for choke valve to be replaced)

Cause: Faulty sealing in lifting cylinder

Remedy: Contact After-Sales Service (arrange for lifting cylinder to be replaced)

---

**Cleaning motor does not work**

Cause: No compressed air supply

Remedy: Establish a compressed air supply

Cause: No signal from robot

Remedy: Check robot program

Cause: Mechanical fault on cleaning motor

Remedy: Contact After-Sales Service (arrange for cleaning motor to be replaced)

Cause: Mechanical fault on solenoid valve

Remedy: Contact After-Sales Service (arrange for solenoid valve to be replaced)

---

# Technical data



# Technical data

<b>Robacta Reamer V Twin</b>	Supply voltage	+ 24 V DC
	Rated power	14.4 W
	Nominal pressure	6 bar 86.99 psi
	Air consumption	440 l/min 465 qt./min
	Compressed air connection thread identification	G ¼"
	Standard I/O (X1)	Input: + 24 V DC / max. 300 mA Output: + 24 V DC / max. 30 mA
	Cleaning time	7.0 - 7.5 s
	Total cycle time	8.5 - 10 s
	Parting agent container capacity	1 l 0.26 gal. (US)
	Protection class	IP 21
	Mark of conformity	CE, CSA
	Safety symbols	S
	'Performance Level'	c
	Max. noise emission (LWA)	82 dB (A)
	Dimensions L x W x H	225 x 400 x 380 mm 8.86 x 15.75 x 14.96 in.
	Weight (without parting agent)	17 kg 37.48 lb.



# Appendix





# Circuit diagram Robacta Reamer V Twin

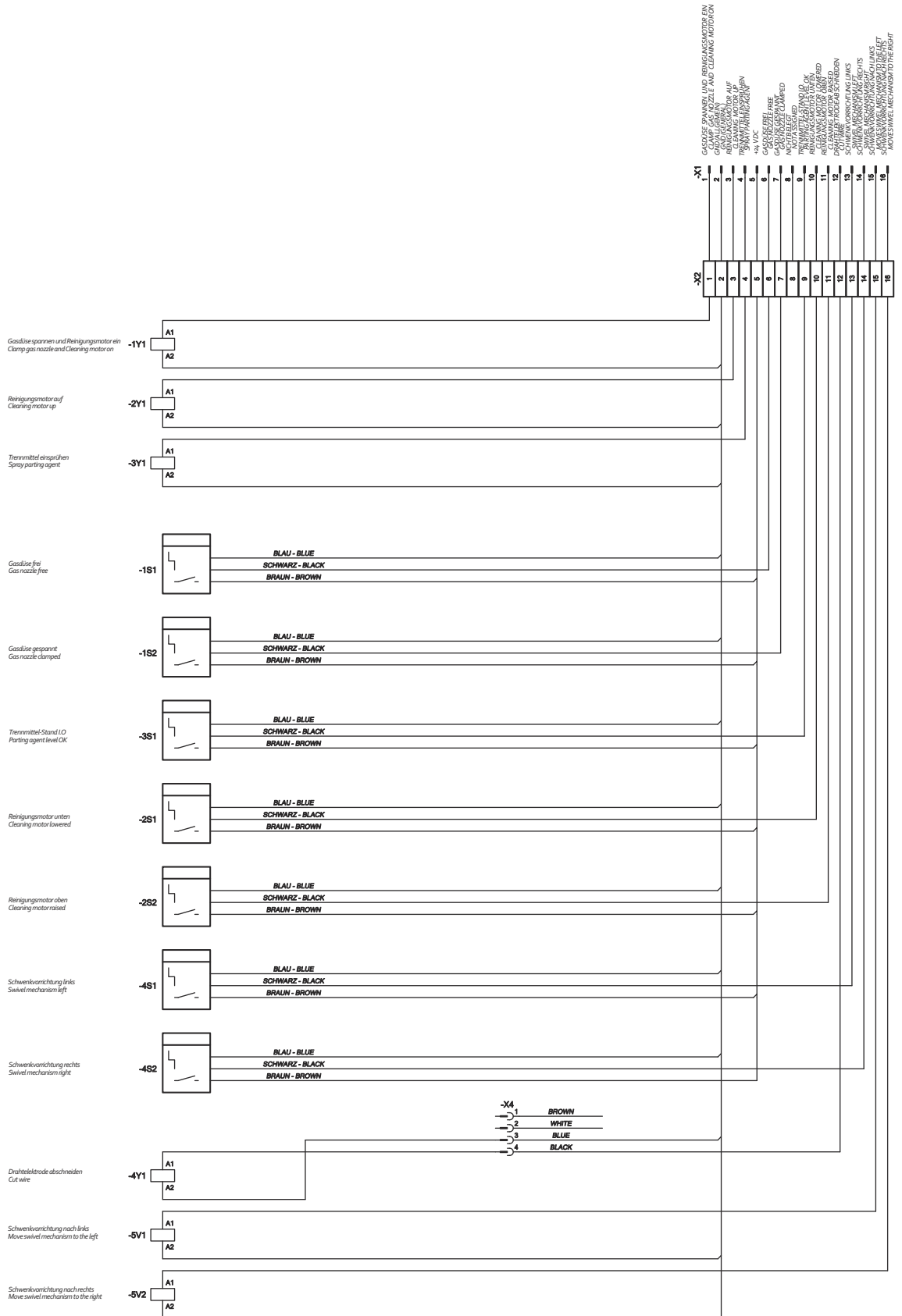

# Robacta Reamer V Twin pneumatic diagram

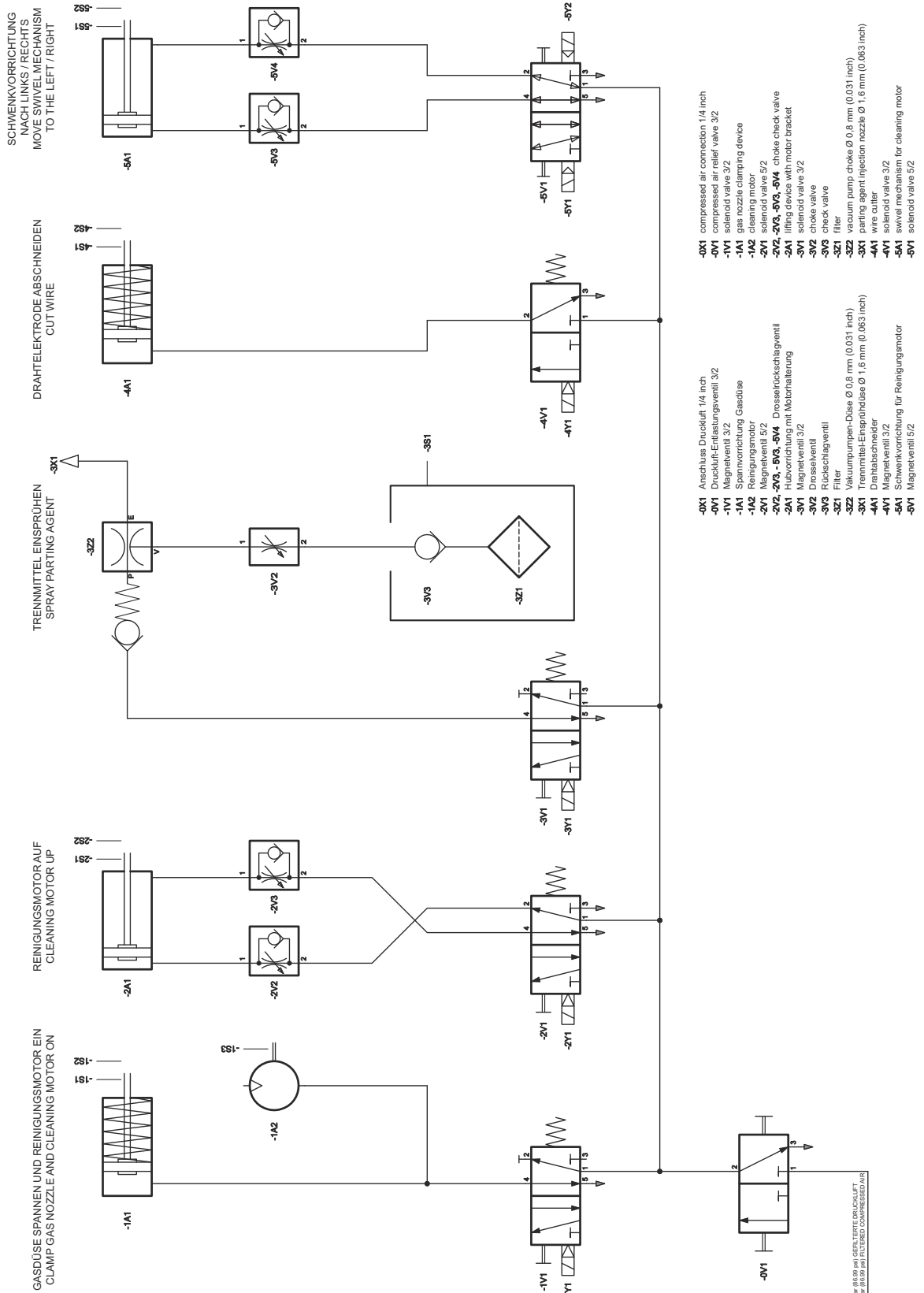

# Declaration of conformity

EN



## EU-KONFORMITÄTSERKLÄRUNG 2016 EU-DECLARATION OF CONFORMITY 2016 DÉCLARATION UE DE CONFORMITÉ, 2016

Wels-Thalheim, 2016-07-07

Die Firma

Manufacturer

La compagnie

### FRONIUS INTERNATIONAL GMBH

Froniusstraße 1, A-4643 Pettenbach

erklärt in alleiniger Verantwortung,  
dass folgendes Produkt:

Hereby certifies on its sole  
responsibility that the following  
product:

se déclare seule responsable du fait  
que le produit suivant:

Robacta Reamer V Twin  
Gasdüsenreinigungsgerät

Robacta Reamer V Twin  
Gas nozzle cleaner

Robacta Reamer V Twin  
Appareil de nettoyage de buses gaz

auf das sich diese Erklärung  
bezieht, mit folgenden Richtlinien  
bzw. Normen übereinstimmt:

which is explicitly referred to by this  
Declaration meet the following  
directives and standard(s):

qui est l'objet de la présente  
déclaration correspondent aux  
suivantes directives et normes:

Richtlinie 2014/30/EU  
Elektromag. Verträglichkeit

Directive 2014/30/EU  
Electromag. compatibility

Directive 2014/30/UE  
Électromag. Compatibilité

Richtlinie 2006/42/EG  
Maschinenrichtlinie

Directive 2006/42/EC  
Machinery Directive

Directive 2006/42/CE  
Directive aux machines

Europäische Normen inklusive  
zutreffende Änderungen  
EN ISO 12100:2010  
EN 61000-6-2:2005+AC:2005  
EN 61000-6-4:2007+A1:2011

European Standards including  
relevant amendments  
EN ISO 12100:2010  
EN 61000-6-2:2005+AC:2005  
EN 61000-6-4:2007+A1:2011

Normes européennes avec  
amendements correspondants  
EN ISO 12100:2010  
EN 61000-6-2:2005+AC:2005  
EN 61000-6-4:2007+A1:2011

Die oben genannte Firma hält  
Dokumentationen als Nachweis der  
Erfüllung der Sicherheitsziele und  
die wesentlichen Schutzanforder-  
ungen zur Einsicht bereit.

Documentation evidencing  
conformity with the requirements of  
the Directives is kept available for  
inspection at the above  
Manufacturer.

En tant que preuve de la satisfaction  
des demandes de sécurité la  
documentation peut être consultée  
chez la compagnie susmentionnée.

Dokumentationsverantwortlicher:  
(technische Dokumentation)

person responsible for documents:  
(technical documents)

responsable documentation:  
(technique documentation)

Ing. Josef Feichtinger  
Günter Fronius Straße 1  
A - 4600 Wels-Thalheim

Ing. Josef Feichtinger  
Günter Fronius Straße 1  
A - 4600 Wels-Thalheim

Ing. Josef Feichtinger  
Günter Fronius Straße 1  
A - 4600 Wels-Thalheim

 2016

ppa. Mag.Ing.H.Hackl  
Member of Board  
Chief Technology Officer



**Fronius International GmbH**

Froniusstraße 1  
4643 Pettenbach  
Austria  
[contact@fronius.com](mailto:contact@fronius.com)  
[www.fronius.com](http://www.fronius.com)

At [www.fronius.com/contact](http://www.fronius.com/contact) you will find the contact details  
of all Fronius subsidiaries and Sales & Service Partners.