



# Quick Start Guide

**Fronius Primo GEN24 208-240**

3.8 - 10.0 kW



42,0410,2417

013-28042024



## EN: WARNING!

Operating the equipment incorrectly or poor workmanship can cause serious injury or damage. The inverter may only be installed and commissioned by trained personnel acting in accordance with the technical regulations. Before working with the device, ensure that you have read and understand all the documents provided (both hard copies enclosed with the product and documents provided online).

## FR: AVERTISSEMENT!

Les erreurs de commande et les erreurs en cours d'opération peuvent entraîner des dommages corporels et matériels graves. L'installation et la mise en service de l'onduleur ne doivent être effectuées que par du personnel formé à cet effet et dans le cadre des dispositions techniques. Ne travailler avec l'appareil que lorsque tous les documents mis à disposition en annexe, imprimés et en ligne, ont été lus et compris !

## ES-MX: ADVERTENCIA!

El manejo incorrecto y los trabajos realizados de forma incorrecta pueden provocar daños personales o materiales graves. La instalación y la puesta en marcha del inversor deben llevarse a cabo exclusivamente por personal formado y en el marco de las disposiciones técnicas. ¡Antes de trabajar con el equipo, leer y comprender todos los documentos adjuntos y puestos a disposición en línea!

## FCC

This equipment has been tested and found to comply with the limits for a Class B digital device, pursuant to part 15 of the FCC Rules. Operation is subject to the following two conditions:

- (1) This device may not cause interference; and
- (2) This device must accept any interference, including interference that may cause undesired operation of the device.

## Rapid Shutdown

Two different types of rapid shutdown (RSD) can be triggered depending on the configuration and on-site installation:

**Via external buttons:** One or more external buttons can be installed on the WSD (wired shutdown) interface of the Data communication area on page (→). Pressing one of these buttons triggers the rapid shutdown. The terminals are discharged to < 30 VDC / 8 A / 240 VA and < 15 VAC / 8 A / 240 VA. The inverter also interrupts the communication to the shutdown devices of the PV modules if they correspond to the SunSpec standard for rapid shutdown.

**Via the loss of the grid connection:** An automatic rapid shutdown can also occur if the grid connection is lost. The inverter identifies a failure of the grid connection and terminals are discharged to < 30 VDC / 8 A / 240 VA and < 15 VAC / 8 A / 240 VA. The inverter also interrupts the communication to the shutdown devices of the PV modules if they correspond to the SunSpec standard for rapid shutdown.

For more information see



## Power Line Communication (PLC) transmitter

The inverter is equipped with a Power Line Communication (PLC) transmitter on the DC side.

Its function is to ensure rapid shutdown in accordance with National Electric Code NEC 2023 Art. 690.12 and Canadian Electrical Code CSA C22.1:21 Art. 64-218. The PLC is implemented according to the specification "Communication Signal for Rapid Shutdown – SunSpec Interoperability Specification". Please visit [www.sunspec.org](http://www.sunspec.org) for details.

## AFCI - Arc Fault Circuit Interrupter (Arc Guard)

An AFCI (arc fault circuit interrupter) protects against arc faults and, in the narrower sense, is a protection device in the event of contact errors. The AFCI evaluates faults that occur in the current and voltage flow on the DC side using an electronic circuit and shuts down the circuit if a contact error is detected. This prevents overheating at poor contact points and, ideally, possible fires.

## DANGER

### Danger from faulty or incorrect DC installation.

This may result in a risk of damage and, as a consequence, risk of fire in the PV system due to prohibited thermal loads that occur during an arc.

- ▶ Check the plug connections to ensure that they are correct.
- ▶ Repair faulty insulation correctly.
- ▶ Perform connection work in line with the instructions.

# Operating Instruction

Fronius Primo GEN24 208-240

3.8 - 6.0



<https://manuals.fronius.com/html/4204260530>

Fronius Primo GEN24 208-240

7.7 - 10.0



<https://manuals.fronius.com/html/4204260312>

## Suitable grids

240 V: 120 V Split Phase  
240 V: 120 V Stinger

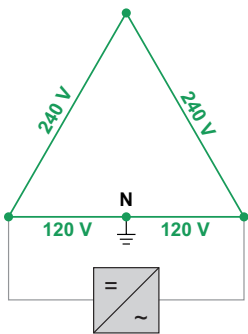

1) 208 V / 120 V WYE  
2) 220 V / 127 V WYE

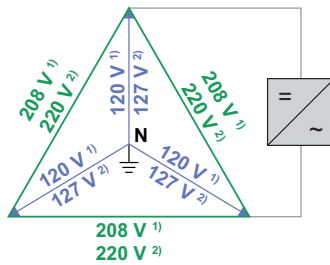

1) 208 V Delta Corner Grounded  
2) 220 V Delta Corner Grounded  
3) 240 V Delta Corner Grounded

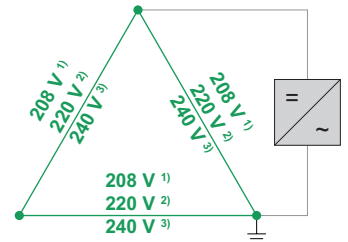

## Warning signs explanation



General warning sign  
Panneau d'avertissement général  
Señal de advertencia general



Electricity hazard  
Risque électrique  
Peligro de electricidad

## Tools

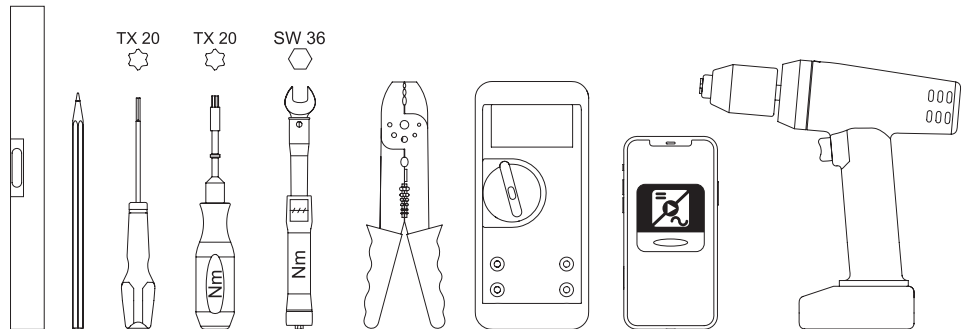

## To note during installation

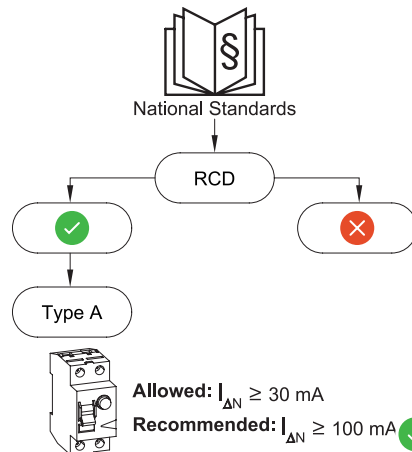
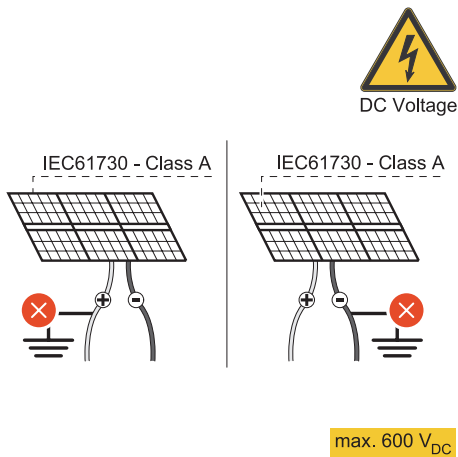

## Rating plate

## Safety information

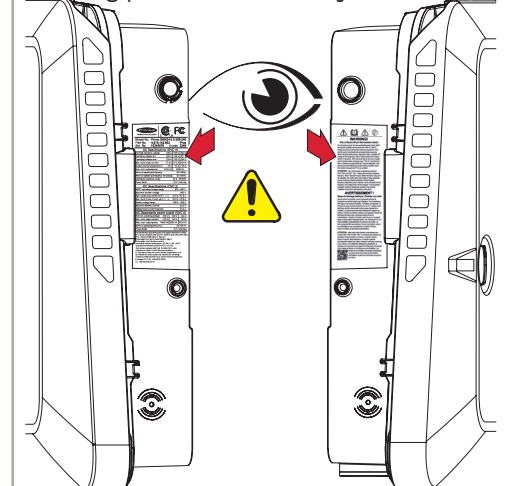

## Mounting conditions

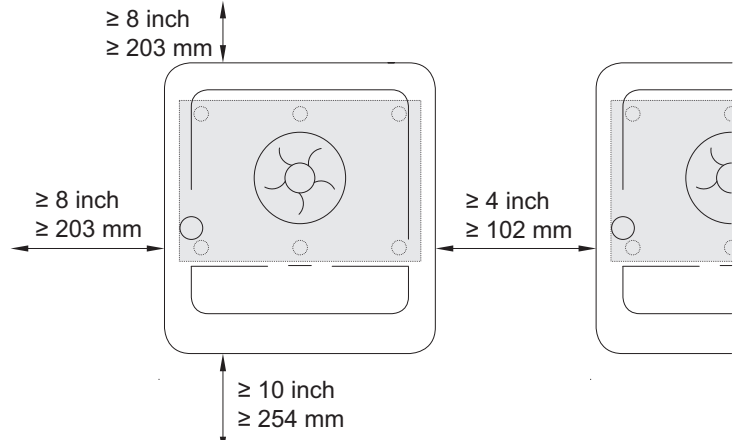
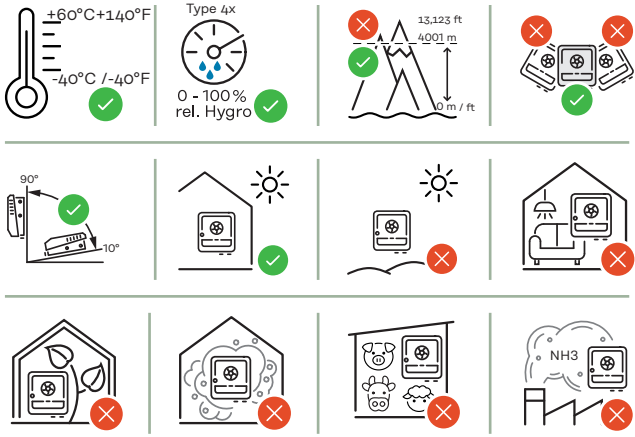

## Mounting

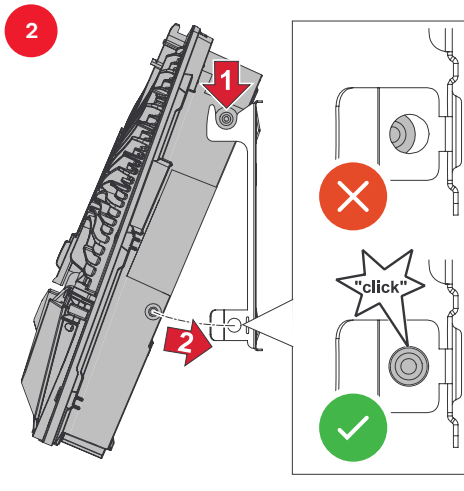
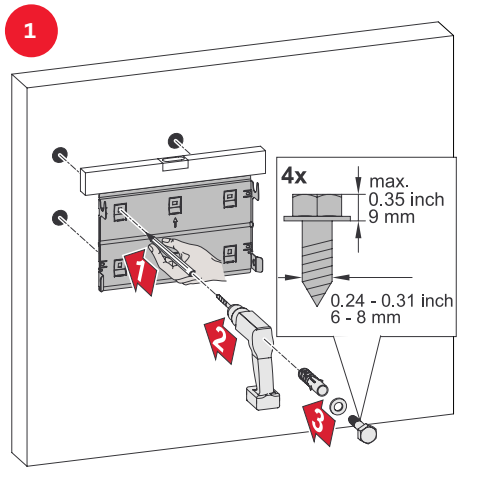

## AC~

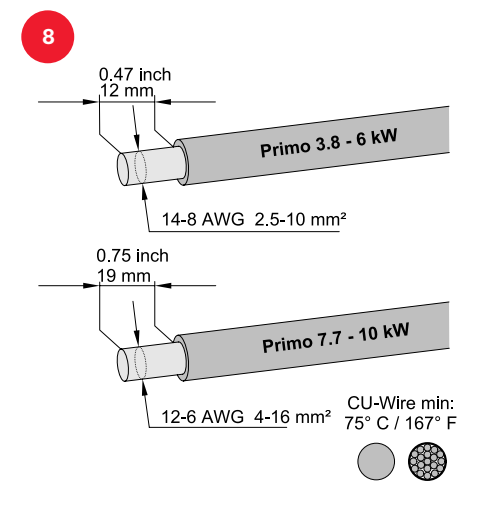
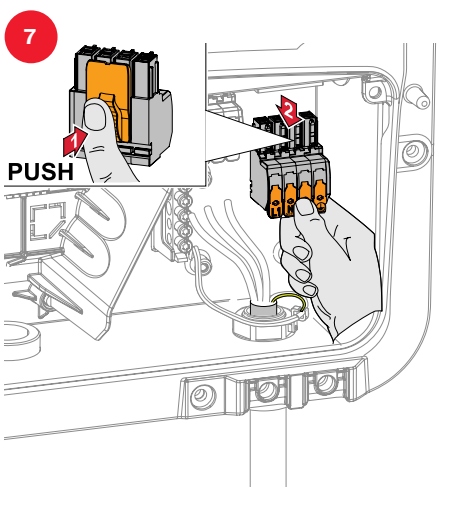
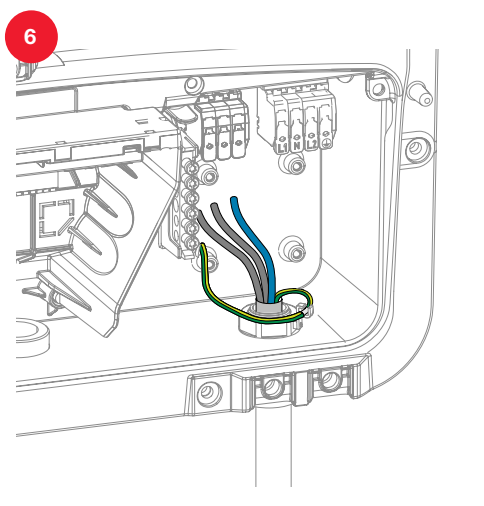
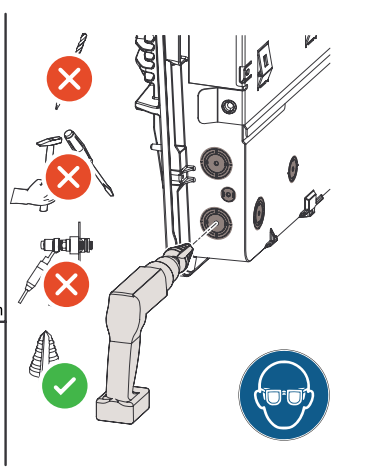
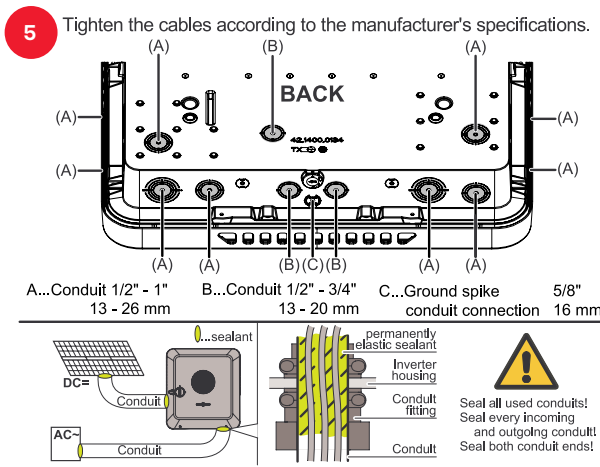
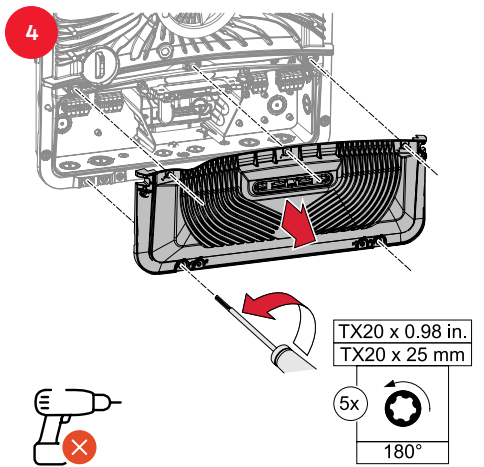
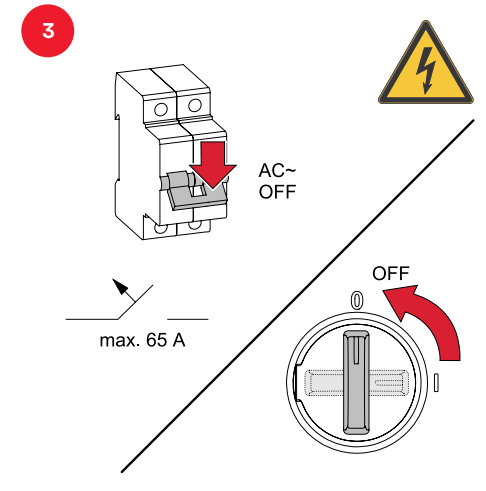

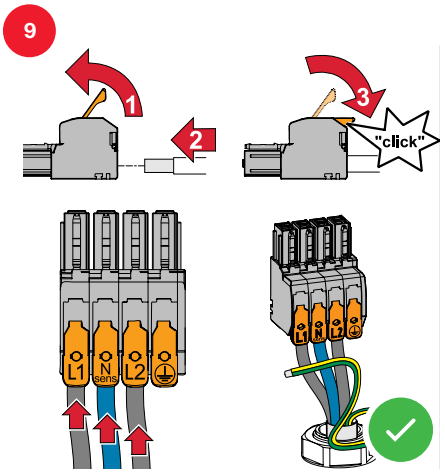

DC=

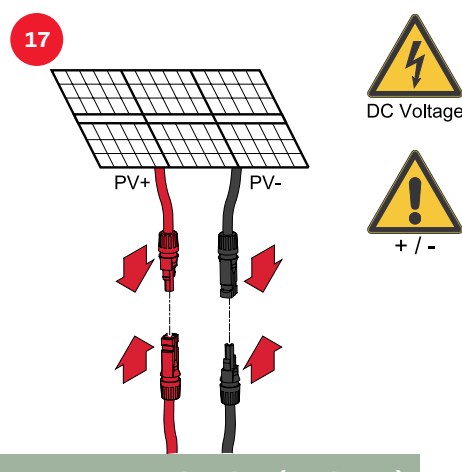
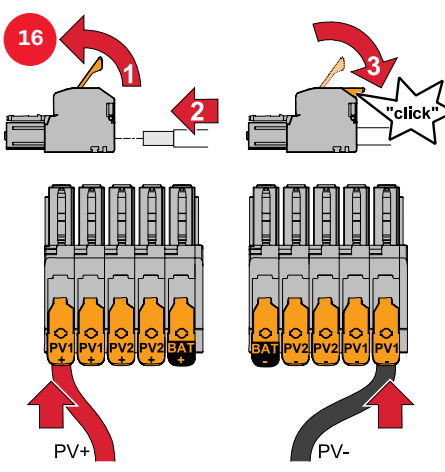
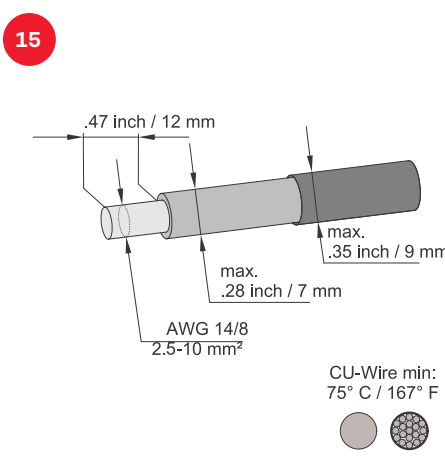
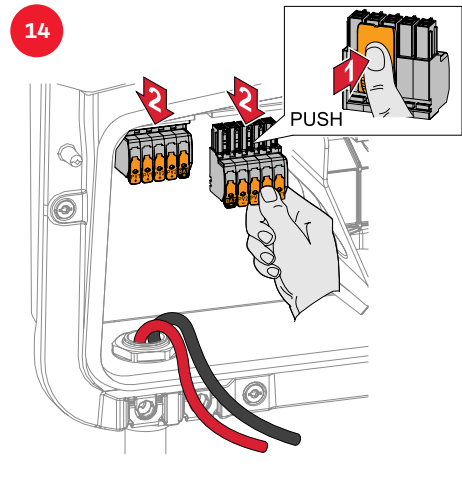
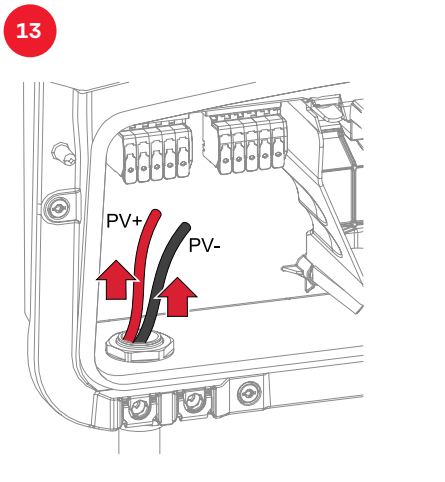
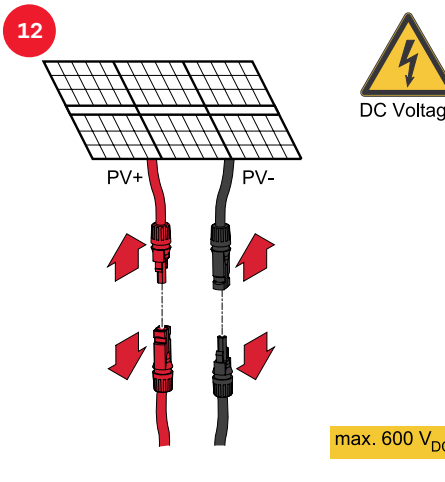
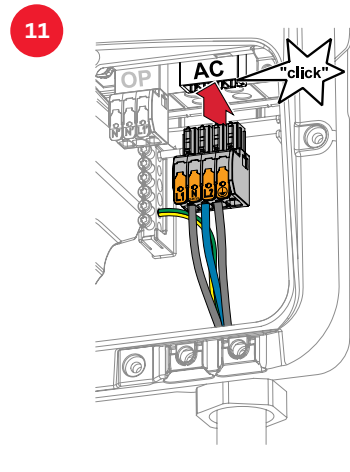
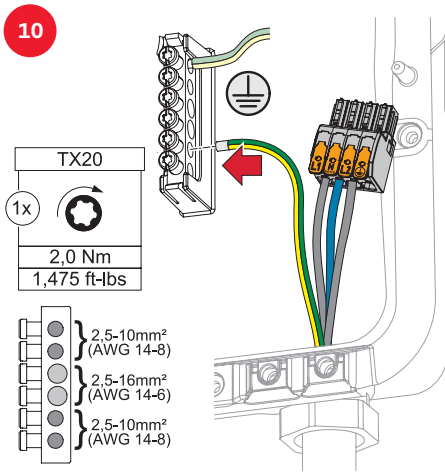

Data communication (optional)

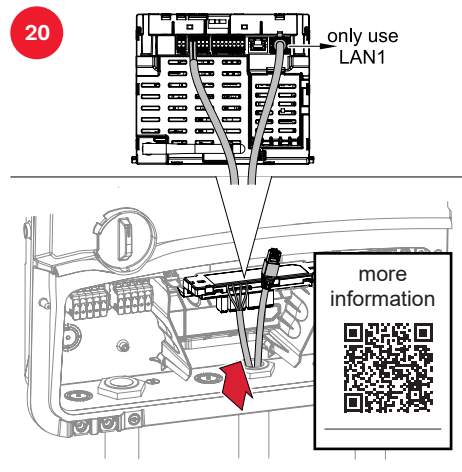
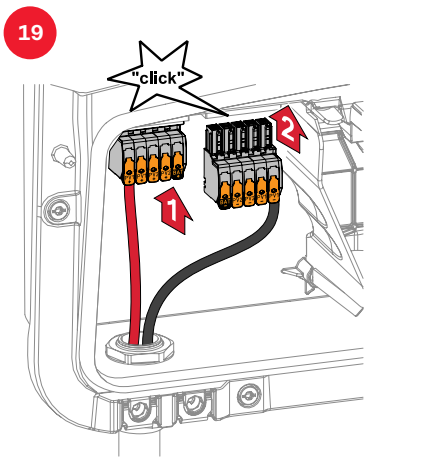
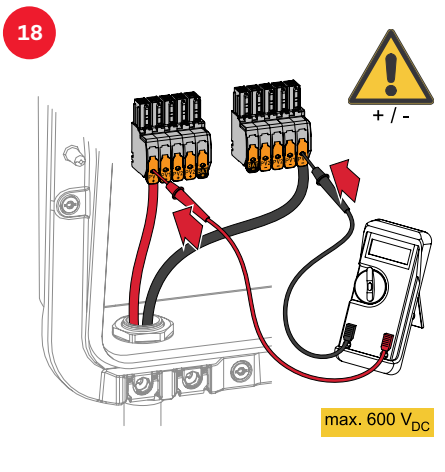

## Commissioning

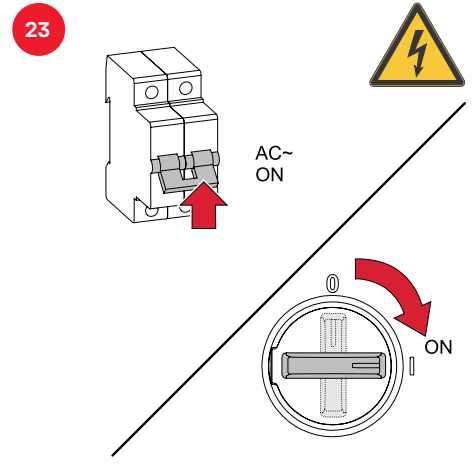
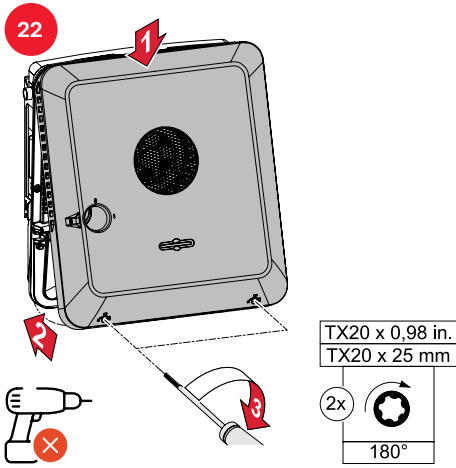
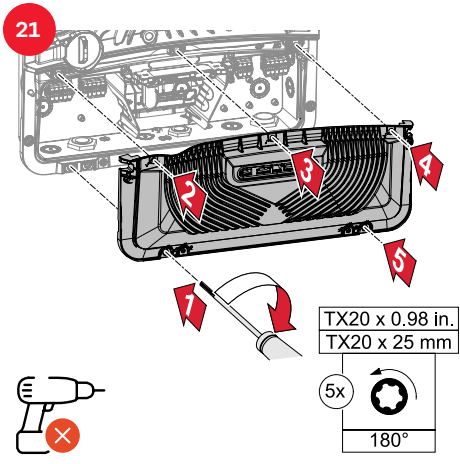

## Control panel

## Setup with mobile phone

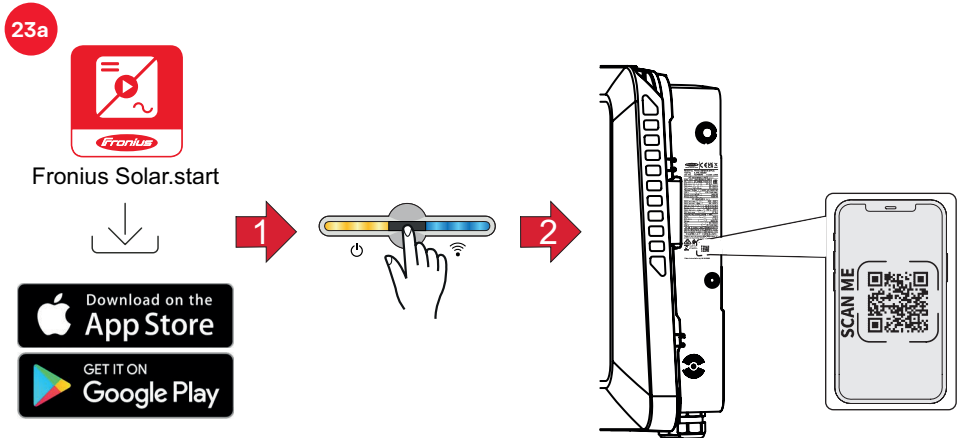
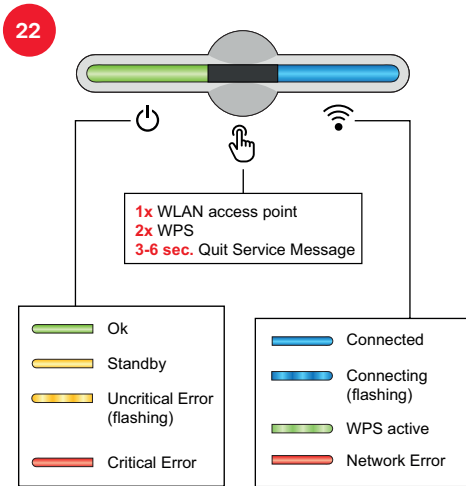

## Setup with PC - Ethernet

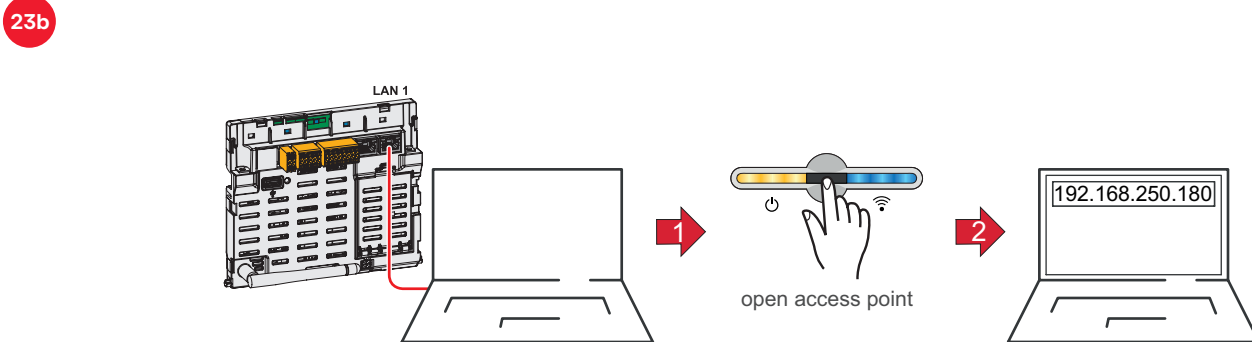

## Setup with PC - WLAN

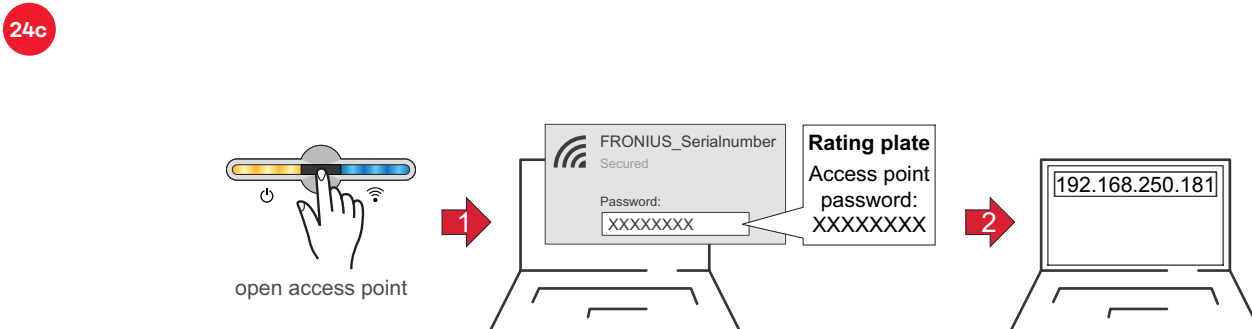

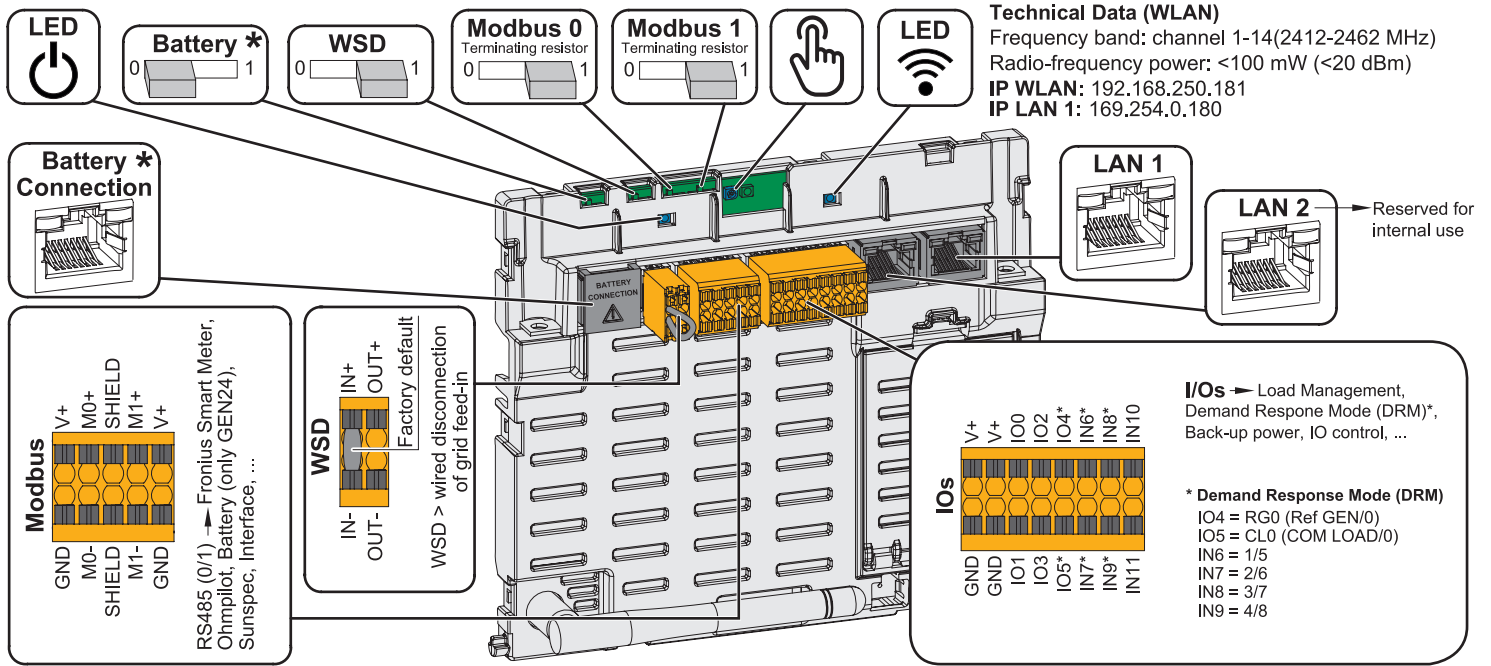

\* Please note that the BAT (RJ45) interface is reserved for future use and not given at the moment.

<b>Fronius Primo GEN24 3.8 - 6.0 208 - 240</b>	
Dimensions (height x width x depth)	20.3 × 18.7 × 6.5 inches (516 × 474 × 165 mm)
Max. short-circuit current ( $I_{sc}$ PV = $I_{sc}$ max)	36 A (MPPT1) / 19 A (MPPT2)
Arc Fault Circuit Interrupter	PV DC Arc-Fault Circuit-Protection Type 1, according to UL1699B:2021
<b>Fronius Primo GEN24 7.7 - 10.0 208 - 240</b>	
Dimensions (height x width x depth)	23.0 × 20.8 × 7.1 inches (583 × 529 × 180 mm)
Max. short-circuit current ( $I_{sc}$ PV = $I_{sc}$ max)	41.25 A (MPPT1) / 36 A (MPPT2)
Arc Fault Circuit Interrupter	PV DC Arc-Fault Circuit-Protection Type 1 according to UL1699B:2021



[fronius.com/en/solar-energy/installers-partners/products-solutions/monitoring-digital-tools](https://fronius.com/en/solar-energy/installers-partners/products-solutions/monitoring-digital-tools)

**MONITORING &  
DIGITAL TOOLS**

**Fronius International GmbH**

Froniusstraße 1  
4643 Pettenbach  
Austria  
[contact@fronius.com](mailto:contact@fronius.com)  
[www.fronius.com](http://www.fronius.com)

Under [www.fronius.com/contact](http://www.fronius.com/contact) you will find the addresses of all Fronius Sales & Service Partners and locations.